

SPIKE MODE OF A GALLIUM ARSENIDE LASER EXCITED BY AN ELECTRON BEAM

O. V. BOGDANKEVICH, V. A. GONCHAROV, Yu. A. DROZHBIN, B. M. LAVRUSHIN,

A. N. MESTVIRISHVILI, and V. A. YAKOVLEV

P. N. Lebedev Physics Institute, Academy of Sciences, U.S.S.R.

Submitted February 13, 1967

Zh. Eksp. Teor. Fiz. 53, 785-788 (September, 1967)

Nonstationary processes are investigated in a semiconductor laser with electron excitation. The time resolution of the apparatus is better than 10^{-10} sec. Gallium arsenide is used as the working substance; the energy of the electron beam is 50 keV. Pulsations of the radiation flux with a period of 0.2-0.4 nsec are observed. They confirm the theory in which spatial inhomogeneity in such a laser is taken into account.

AS is well known, in pulsed operation of any laser with a finite time of establishment of oscillations of the optical resonator T_1 ($T_1 \approx 1/\Delta f$, Δf is the width of the mode), and a finite lifetime of the active particles in the excited state T_2 , the establishment of a quasistationary state is preceded by a transient process in the form of damped intensity oscillations. The length of this process and the period of the oscillations depend on the extent to which the excitation level exceeds the generation threshold and on the absolute values of T_1 and T_2 .

It is also known that quasistationary operation may turn out to be unstable and the system then goes over to the auto-modulating regime (spike mode). This regime is characterized by the presence of regular and irregular energy pulsations of the field in the resonator and of the emission power. The spike regime in the case of lasers with luminescent crystals and glasses has been investigated in detail both theoretically and experimentally. In particular, it has been shown that the basic reasons for the instability of the quasistationary regime are in the first place the inhomogeneity of the spatial distribution of the excitation, and in the second place the interaction of the quasidegenerate modes of the optical resonator (for example, modes with the same longitudinal but different transverse indices) through the active medium. In the first case the spike regime is connected with a redistribution of the energy of the optical field within the volume of the active substance, and in the second case—with a redistribu-

tion of the energy among the modes interacting through the substance¹⁾ [1-3]

In view of the fact that in the case of the commonly used excitation scheme of a semiconductor laser by an electron beam with an energy of some tens keV the inhomogeneity of excitation turns out to be very strong, one must expect the existence of a spike regime in such a laser.

The effects of the inhomogeneity of excitation of a semiconductor laser have been investigated theoretically and experimentally in^[5]. The theoretical treatment of these effects was carried out by numerical integration of the wave equation with corresponding boundary conditions. Along with other effects of inhomogeneity, numerical calculations indicated the possibility of the existence of both damped and undamped pulsations of the emission intensity. An example of pulsations constructed on the basis of these calculations is shown in Fig. 1. For the values of the constants assumed in that paper, the period of the pulsations amounts to 0.1-0.3 nsec when the generation threshold is exceeded by a factor of 2-10.

In our work we have observed experimentally the existence of pulsations of the emission intensity of a semiconductor laser, the nature of the pulsations corresponding to the theory. As the working substance of the laser we employed single-crystal gallium arsenide

¹⁾The auto-modulating regime has also been observed in injection semiconductor lasers [4] but received no interpretation.

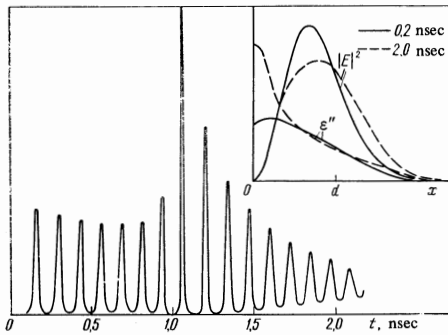

FIG. 1. Theoretical time dependence of the total energy of the field in the resonator (lower curve), and the distribution of the imaginary part of the dielectric constant (describing the enhancement) and the energy of the field at the most characteristic times (upper curves).

alloyed with tellurium to a concentration of 10^{18} cm^{-3} . At $T = 300^\circ\text{K}$ the mobility was $\mu = 300 \text{ v/cm}^2\text{-sec}$. The samples were in the form of a right parallelepiped (Fig. 2). The face ABCD and the face opposite to it were polished and formed the optical resonator. The resonator dimension was $L = AE = (0.528 \pm 0.014) \text{ mm}$.

A pulsed electron beam was used for pumping (electron energy 50 keV, pulse length 150 nsec, repetition rate 50 cps). The face illuminated by the electrons (ACEF) was also polished. The dimensions of the active region (hatched on Fig. 2) were: $ab < 10 \mu$, and $ac = 100\text{--}400 \mu$. The first dimension was determined by the depth of penetration of the electrons, while the second was determined both by the cross sectional dimension of the electron beam and the quality of the resonator. The existence of rather large cleavages on the AC face leads to the possibility of simultaneous generation in several separate resonator regions.

The generating region of the crystal (abcd on Fig. 2) was projected with the aid of an optical system with magnification close to unity onto the photocathode of a photoelectric detector (PED). The electron optics of the PED insured the transfer of this image onto a luminescent screen with simultaneous time sweep. The time sweep of the image and the photography of the process on the luminescent screen was carried out in such a way that each frame of film corresponded to a single pumping pulse. The time resolution of the described technique is no worse than 10^{-10} sec .

Photographs of the time sweep of the image of the region of generation are presented in Fig. 3. Here the

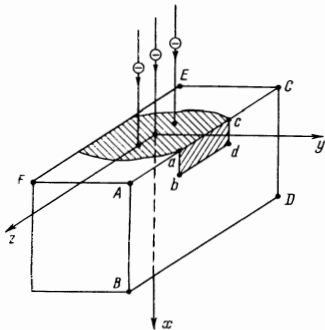

FIG. 2. Excitation scheme of the semiconductor laser and the basic notation.

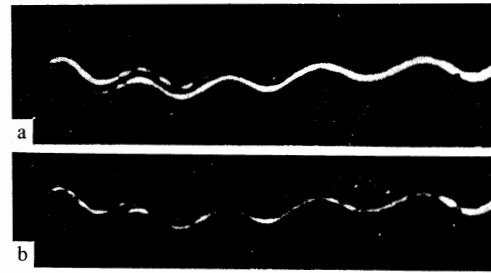

FIG. 3. Time distribution of the emission intensity of a semiconductor laser (photographs from the PED screen with different exposures).

time sweep is along the horizontal, and the extent of the illumination of the photographic emulsion characterizes the instantaneous light intensity. The sine curve on this diagram characterizes the scale of the time sweep. The period of the sine curve amounts to $1.6 \text{ nsec} \pm 10 \text{ percent}$. The two sweep lines correspond to two separate regions of generation. It should be noted that since the current pulse has as a function of time a bell-like shape, different time intervals of the pulse correspond to different degrees of excess over the generation threshold. For this reason the period of the pulsations turns out to be larger at the beginning and at the end of the light pulse. Figure 3 corresponds to a sixfold excess of the generation threshold at the pulse maximum.

From the experiments that have been carried out one can draw the following conclusions.

1. The emission of a semiconductor laser pumped by an electron beam exhibits intensity pulsations.
2. These pulsations can be both regular and irregular. The nature of the pulsations depends on the excess over the generation threshold.
3. In the case of the regular pulsations their period amounts to $0.25\text{--}0.40 \text{ nsec}$, which is in satisfactory agreement with the theoretical values of^[5].

¹A. F. Suchkov, Zh. Eksp. Teor. Fiz. **49**, 1495 (1965) [Sov. Phys.-JETP **22**, 1026 (1966)].

²V. S. Letokhov and A. F. Suchkov, Zh. Eksp. Teor. Fiz. **50**, 1148 (1966) [Sov. Phys.-JETP **23**, 763 (1966)].

³N. G. Basov, V. N. Morozov, and A. N. Oraevskii, Dokl. Akad. Nauk SSSR **162**, 781 (1965); Zh. Eksp. Teor. Fiz. **49**, 895 (1965) [Sov. Phys.-Dokl. **10**, 516 (1965); Sov. Phys.-JETP **22**, 622 (1966)].

⁴V. D. Kurnosov, V. I. Magalyas, A. A. Pleshkov, L. A. Rivlin, V. G. Trukhan, and V. V. Tsvetkov, ZhETF Pis. Red. **4**, 449 (1966) [JETP Lett. **4**, 303 (1966)].

⁵O. V. Bogdankevich, V. A. Goncharov, B. M. Lavrushin, V. S. Letokhov, and A. F. Suchkov, Fiz. Tekh. Poluprov. **1**, 7 (1967). [Sov. Phys.-Semicond. **1**, 4 (1967)].