

## STIMULATED RAMAN AND BRILLOUIN SCATTERING IN SELECTIVE RESONATORS

E. B. ALEKSANDROV, A. M. BONCH-BRUEVICH, N. N. KOSTIN, and V. A. KHODOVOI

Submitted to JETP editor June 15, 1965

J. Exptl. Theoret. Phys. (U.S.S.R.) 49, 1435-1444 (November, 1965)

Stimulated Raman scattering is investigated in benzene, in a cell placed in the cavity of a ruby laser. It is shown that the threshold power and the laser pulse energy required for the observation of the effect decrease with increasing length of the cell. An experimental verification is given to the theoretical prediction that the use of selective resonators increases the efficiency of the stimulated Raman scattering. Stimulated Brillouin scattering was observed in benzene, carbon bisulfide, and nitrobenzene at  $90^\circ$  to the exciting beam. The use of a transverse selective resonator allows observation of stimulated Brillouin scattering at appreciably lower excitation power than reported earlier.

## 1. INTRODUCTION

IN view of the progress in laser development, interest in Raman scattering (RS) has sharply increased in recent years.<sup>[1,2]</sup> The use of lasers makes it possible to determine the absolute values of the capture cross-sections for RS.<sup>[3]</sup> Lasers working at various frequencies make it possible to determine the frequency dependence of RS near the electron absorption bands. The discovery of the stimulated Raman scattering (SRS) is of great interest, since it makes it possible to transform into RS lines an appreciable part (of the order of 10%) of the exciting radiation energy. It seems that techniques of generating optical harmonics combined with SRS<sup>[4]</sup> will result in intense sources of coherent radiation in the optical range.

Initially SRS was observed under giant pulses, and thereafter also in the usual pumping mode of a ruby laser<sup>[5,6]</sup>. The conditions of effective transformation of the laser radiation into SRS are not yet clear enough. We have made a comparative investigation of SRS at low (close to threshold) excitation power. Two new schemes for the observation of SRS with longitudinal and transverse selective resonators, which were suggested independently of other authors were studied<sup>1)</sup>. In these schemes effective SRS at relatively low exciting radiation power is made possible by a decrease in the resonator losses and by reduction of its length. In our investigation we observed stimulated Brillouin scattering at much lower excitation power than reported earlier<sup>[10-12]</sup>.

## 2. ESTIMATE OF FEASIBILITY OF EFFICIENT SRS

If the exciting-radiation density is high enough to make the stimulated emission of photons in the mode  $\beta$  much greater than their loss then, according to quantum theory, for the usual scheme of SRS observation (Fig. 1a), the change in the number of photons in this mode is given by the equation<sup>[13,14]</sup>

$$dn_\beta / dt = n_\beta(\alpha_\beta l - \gamma_\beta) / \tau_\beta. \quad (1)$$

Here  $\alpha_\beta$  is the amplification coefficient of the number of photons  $n_\beta$  per unit length of the cell,  $l$  is the length of the cell,  $\gamma_\beta$  is the average fraction of photons lost in the  $\beta$  mode during one passage through the resonator, and  $\tau_\beta$  is the time of this passage. The quantity  $\alpha_\beta$  is proportional to the density of the laser radiation in the resonator; it is of the order of  $0.1 \text{ cm}^{-1}$  for liquids most active to SRS, at a  $100 \text{ MW/cm}^2$  ruby laser intensity. Generally speaking,  $\alpha_\beta$  depends on the number of photons  $n_\beta$ , because SRS affects the generation of radiation in the laser. We restrict ourselves to the case of a small loss ( $\leq 10\%$ ) of photons from the laser pulse, which is assumed to be rectangular and of duration  $\Delta t$ , and assume that  $\alpha_\beta = \text{const} \neq 0$  for  $0 < t < \Delta t$ . Integration of (1) then yields for the number  $n_\beta$  during the laser pulse:

$$n_\beta(\Delta t) = n_\beta(0) \exp(\alpha_\beta l - \gamma_\beta) \Delta t / \tau_\beta = n_\beta(0) \exp D, \quad (2)$$

where  $n_\beta(0)$  is the number of photons in the  $\beta$  mode at  $t = 0$ . It was shown in<sup>[14]</sup> that with sufficient accuracy one may assume  $n_\beta(0) = 1$ . Expression (2) has a simple physical meaning: if there are initially  $n_\beta(0)$  photons in each  $\beta$  mode,

<sup>1)</sup>See also [7-9].

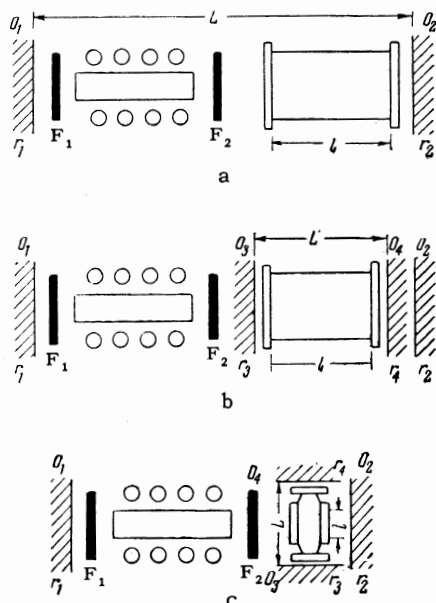

FIG. 1. Setups for the observation of SRS. a—SRS in the laser resonator; b—SRS in a longitudinal selective resonator; c—SRS in a transverse selective resonator.  $L$  is the resonator length for scattered radiation,  $l$  is the active path length of the scattered radiation in the resonator,  $O$  are mirrors,  $F$  are bleaching filters, and  $r$  is the reflection coefficient.

then after one passage through the resonator their number grows  $\exp(\alpha\beta l - \gamma\beta)$  times;  $\Delta t/\tau\beta$  is the number of such passages during one laser pulse.

The condition for an exponential growth of  $n\beta(t)$  is obviously  $\alpha\beta l - \gamma\beta > 0$ . If the loss of transformed photons during one passage through the resonator is represented by  $\gamma\beta = \alpha_L l + \gamma$ , where  $\alpha_L$  is the loss factor in the cell, and  $\gamma$  represents the other losses which are independent of  $l$ , then for the observation of SRS it is necessary that  $\alpha\beta l > \alpha_L l + \gamma$ . In most liquids in which intense SRS is observed,  $\alpha_L$  is  $10^{-4}$ – $10^{-3}$   $\text{cm}^{-1}$  for  $\lambda > 600$  nm<sup>[15]</sup>, and thus even for  $l \approx 100$  cm the internal losses in these liquids remain small in comparison with the external losses under usual conditions of SRS observation, and, therefore, the threshold radiation power required for SRS decreases with increasing  $l$ . The minimum threshold, which is independent of  $\gamma$ , is achieved when the internal losses exceed the external ones, i.e.,  $\alpha_L l \gg \gamma$ , and the condition  $D > 0$  turns into  $\alpha\beta > \alpha_L$ . For benzene at the ruby-laser wavelength  $\alpha\beta \approx 0.004 I_0$ ,<sup>[2,14]</sup> where  $I_0$  is the intensity of exciting radiation in  $\text{MW}/\text{cm}^2$ . For  $\alpha_L = 4 \times 10^{-4}$   $\text{cm}^{-1}$ ,<sup>[15]</sup> the minimum threshold intensity is  $I_0 = 100$   $\text{kW}/\text{cm}^2$ .

To transform a sufficient part of the radiation into a Raman line,  $D$  should not only be positive

but also larger than a certain  $D_{\text{eff}}$ .  $D_{\text{eff}}$  can be easily estimated: e.g., when the laser energy is 1J, and 10% of this energy has to be transformed,  $D_{\text{eff}} \approx 30$  for a number of modes  $\beta \sim 10^4$ ; this corresponds to<sup>[14]</sup>  $n\beta(\Delta t) \approx 10^{13}$ . To fulfill the condition  $D \geq D_{\text{eff}}$  for a given effective amplification equal to  $\exp(\alpha\beta l - \gamma\beta)$  during one passage, the number of passages  $\Delta t/\tau\beta$  should be large enough during the laser pulse. This requirement follows from the essentially nonstationary conditions of SRS at a limited duration of the exciting pulse, and restricts the minimum length of the exciting pulse. Optimum is achieved when the whole resonator is filled with a substance which is active to SRS, i.e.,  $\tau\beta = l/cn\beta$  where  $n\beta$  is the refractive index of the scattered light. Then for  $\alpha\beta l \gg \gamma\beta$ ,  $D = \alpha\beta cn\beta \Delta t$  does not depend on the cell length  $l$ ; at a given power,  $\Delta t$  is the minimum pulse length required for an efficient transformation. In benzene for  $D \approx 30$  and  $I_0 = 100$   $\text{kW}/\text{cm}^2$  the corresponding minimum duration is  $\Delta t_{\text{min}} = 2 \times 10^{-6}$  sec. Therefore the intensity of giant pulses of 20–30 nsec duration should exceed the minimum threshold for efficient transformation by about two orders of magnitude.

Conditions near to optimum for efficient transformation at near-threshold powers are realized in setups with selective resonators (Figs. 1b, 1c). In the first setup, with a longitudinal selective resonator, (Fig. 1b) the mirrors  $O_1$  and  $O_2$  should have the largest possible reflectance for the exciting beam and be transparent for the transformed radiation; the mirrors  $O_3$  and  $O_4$ , closest to the cell, should be transparent for the ruby beam and have optimum transmittivity for the transformed radiation. In the second setup, with the transverse resonator, the selectivity is achieved by separating the directions of the exciting and scattered radiation. This reduces the required selectivity of the mirror reflectance, which is essential when the transformed lines have frequencies close to the exciting radiation. In both schemes the losses of the transformed radiation in the laser crystal are eliminated, and the number of passages of the transformed beam through the active medium is simultaneously increased. Results of the experimental investigation of SRS under usual conditions as well as with selective resonators are presented below.

### 3. SRS WITH CELL PLACED IN THE LASER CAVITY (Fig. 1a)

The exciting radiation was produced with giant ruby laser pulses (crystal length 10–12 cm,

diameter 12–16 mm). Bleaching filters, made of KS-19 glass<sup>[16]</sup>, were placed in the resonator at both ends of the ruby rod. The initial transmittivity of the filters at  $\lambda = 694$  nm changed from 10% to 80%. This method of automatic Q-switching made it possible to obtain single pulses with effective intensity inside the resonator up to  $100 \text{ MW/cm}^2$ , and of duration 20 to 200 nsec. The maximum pulse energy was 5–6J. SRS was observed in benzene ( $992 \text{ cm}^{-1}$  line), in nitrobenzene ( $1332 \text{ cm}^{-1}$  line), and in cyclohexane ( $2852 \text{ cm}^{-1}$  line), but the transformation was studied in detail only in benzene, to which all the following results pertain. To investigate SRS in benzene we used for the reflectors  $O_1$  and  $O_2$  two identical dielectric mirrors, having transmittivity 0.4% at  $\lambda = 694$  nm, 0.8% at  $\lambda = 745$  nm (the fundamental SRS line in benzene), 40% at  $\lambda = 805$  nm (first harmonic), and 70% at  $\lambda = 875$  nm (second harmonic). The radiation from one mirror was registered by a photocell (F-5), the signal of which was photographed from the screen of an oscilloscope (S1-7). The radiation through the second mirror was registered by a spectrograph (STÉ-1) on a photoplate with maximum sensitivity to 840 nm. This allowed the simultaneous registration of the 600–900 nm spectral range. The sensitivity of both detecting systems was sufficient to observe one part in  $10^4$  of the laser single-pulse energy (detection threshold). To record the radiation in a certain SRS line with the oscilloscope, suitable filters were placed in the path of the light beam.

To compare quantitatively the experimental data with theory one should know the powers of the exciting and scattered radiation. These are estimated from the intensity of radiation emerging through one of the mirrors, assuming that the radiation power is constant along the resonator. The last assumption is true in the steady state,<sup>[17]</sup> the conditions of which are fulfilled when the number of the beam passages in the resonator during the pulse is larger than 10.

The SRS development is as follows: up to some threshold energy of the exciting pulse the SRS cannot be observed at all; above it, following merely a (1.5–2)-fold increase in the energy of the exciting pulse, the energy transformed into the fundamental line ( $\lambda = 745$  nm) increases by three orders of magnitude; this energy saturates at a level about 10% of the energy of the exciting pulse, and the next RS lines (harmonics) appear; the energy of these lines grows rapidly up to the energy of the fundamental SRS line and saturates.

When the transformation is very efficient and there appear one or more SRS lines having about 10% energy of the "original" exciting pulse (with no benzene cell in the resonator), either the duration and intensity of the laser pulse decrease sharply, or else dips appear on the pulse. This indicates that the SRS exerts a strong reaction on the development of the exciting laser pulse. At a given energy of the exciting pulse, a higher transformation efficiency was observed in pulses with higher intensity, indicating losses of scattered radiation in the laser resonator.

Increasing the length of the cell decreases the exciting-pulse power and energy required for SRS. SRS is not obtained at  $l \leq 1$  cm, is unstable at  $l = 2$  cm, and stable at  $l = 5 - 60$  cm. For  $l = 60$  cm, SRS is observed with high transformation efficiency (on the order of 10%) in a few spikes of the usual spiking regime of the laser (intensity  $0.5 \text{ MW/cm}^2$ ,  $\Delta t = 300$  nsec). The longer the cell, the less the above-threshold energy at which the harmonics of RS appear. The table shows conditions under which the threshold radiation energy was observed in the fundamental SRS line of benzene (the energy is in the order of  $10^{-4}$  of the energy of the laser pulse). The value of the negative optical density  $D$  serves as a criterion for comparing the experimental data with theory. The values of  $D$  in the table are calculated without account of the losses in the transformed radiation, assuming a uniform power distribution over the cross-section  $S$  of the exciting beam ( $D = 0.004 I_0 S l \Delta t / \tau \beta$ ). The values of  $D$  obtained in this way are smaller than those predicted by Eq. (2), the largest discrepancy occurring when the cell is shortest,  $l = 5$  cm. This discrepancy is apparently related to the nonuniformity of the instantaneous power distribution across the laser beam (the integral distribution, i.e., averaged over the pulse duration  $\Delta t$ , was measured and found to be approximately uniform), and to the interference effects occurring during SRS, and due to the multimode structure of the laser radiation pulse<sup>[18]</sup>. These effects are the stronger the lower the intensity threshold for the observation of scattered radiation. At a  $10^{-2}$  rad divergence of the exciting and scattered beams (the value measured in our experiments), interference effects with the participation of all beam directions manifest themselves for cell lengths up to 1 cm, and when the number of modes in the exciting pulse is  $10^3 - 10^4$  (as in our experiment), these effects cause an additional (8–12)-fold increase in the amplification coefficient  $\alpha_\beta$ . For a cell with

Conditions of transforming the ruby-laser pulse into the 745 nm benzene line in different settings  
(the ruby crystal is 110 mm long, 13 mm in diameter;  $10^{-4}$  of the laser pulse energy is transformed)

SRS in the laser resonator (Fig. 1a)	SRS in selective resonator	
	longitudinal (Fig. 1b)	transverse (Fig. 1c)
$D = 12$	$D = 8$	$D = 20$
$l = 60$ cm $L_{\text{eff}} = 150$ cm* $I_0 = 1.8$ MW/cm <sup>2</sup> $\Delta t = 70$ nsec $E = I_0 \cdot S \cdot \Delta t = 0.25$ J $r_1 = r_2 = 99.2\%$ $(\lambda = 745$ nm)	$l = 60$ cm $L_{\text{eff}} = 90$ cm $I_0 = 0.5$ MW/cm <sup>2</sup> $\Delta t = 100$ nsec $E = 0.1$ J $r_1 = r_2 = 99.2\%$ ( $\lambda = 745$ nm) $r_3 = 40\%$ ( $\lambda = 694$ nm) $r_3 = 99.4\%$ ( $\lambda = 745$ nm)	$l = 1.4$ cm $L_{\text{eff}} = 5.5$ cm (minimum) $I_0 = 10$ MW/cm <sup>2</sup> $\Delta t = 30$ nsec $E = 0.6$ J $r_3 = r_4 = 99.2\%$ $(\lambda = 745$ nm)
$D = 15$	$D = 20$	$D = 30$
$l = 20$ cm $L_{\text{eff}} = 90$ cm $I_0 = 4$ MW/cm <sup>2</sup> $\Delta t = 70$ nsec $E = 0.55$ J $r_1 = r_2 = 99.2\%$ $(\lambda = 745$ nm)	$l = 20$ cm $L_{\text{eff}} = 30$ cm $I_0 = 2.5$ MW/cm <sup>2</sup> $\Delta t = 55$ nsec $E = 0.3$ J $r_1 = r_2 = 99.2\%$ ( $\lambda = 745$ nm) $r_3 = 40\%$ ( $\lambda = 694$ nm) $r_3 = 99.4\%$ ( $\lambda = 745$ nm)	$l = 1.4$ cm $L_{\text{eff}} = 13$ cm (minimum) $I_0 = 70$ MW/cm <sup>2</sup> $\Delta t = 15$ nsec $E = 2.0$ J $r_3 = r_4 = 99.2\%$ $(\lambda = 745$ nm)
$D = 5$	$D = 15$	
$l = 5$ cm $L_{\text{eff}} = 60$ cm $I_0 = 5.5$ MW/cm <sup>2</sup> $\Delta t = 45$ nsec $E = 0.5$ J $r_1 = r_2 = 99.20\%$ $(\lambda = 745$ nm)	$l = 5$ cm $L_{\text{eff}} = 10$ cm $I_0 = 2.5$ MW/cm <sup>2</sup> $\Delta t = 40$ nsec $E = 0.2$ J $r_1 = r_2 = 99.2\%$ ( $\lambda = 745$ nm) $r_3 = 40\%$ ( $\lambda = 694$ nm) $r_3 = 99.4\%$ ( $\lambda = 745$ nm)	

\* $L_{\text{eff}} = c\tau\beta$  is the effective length of the resonator.

$l = 5$  cm this can give an apparent (2–3)-fold decrease in  $D$ .

The observed strong dependence of the transformation efficiency on small changes in the ruby beam energy when the threshold is substantially exceeded, when  $\alpha\beta l \gg \gamma\beta$ , follows directly from Eq. (2). For 10% transformation efficiency, a 1.5-fold decrease in pulse energy should lead to a 1.5-fold decrease in the factor  $D$ , and, therefore, to a decrease in transformation efficiency by 3–4 orders of magnitude, as was observed experimentally.

#### 4. SRS IN A LONGITUDINAL SELECTIVE RESONATOR (Fig. 1b)

To reduce the losses  $\gamma\beta$ , and to increase the number of passages  $\Delta t/\tau\beta$  of the transformed beam, a setup was used (Fig. 1b) in which the mirrors  $O_1$  and  $O_2$  were the same as before, the mirror  $O_4$  was omitted and its role assumed by

$O_2$ , and the mirror  $O_3$  had a large transmittance at  $\lambda = 694$  nm and a minimum at  $\lambda = 745$  nm. We obtained a transformation efficiency not lower than in the previous case at all cell lengths,  $l = 5, 20, 60$  cm, and for considerably lower powers and energies of the laser pulse. A characteristic feature of SRS in this resonator is the appearance of the RS harmonics at even smaller excesses over the threshold power for SRS than in the preceding case. Increasing the power above the threshold leads faster to the saturation of the SRS lines and to the shortening of the exciting pulse. For example, in the setup of Fig. 1a, without the benzene cell, the laser gave 40 nsec pulses of 200 MW power in a resonator 110 cm long. When a cell with  $l = 20$  cm and the mirror  $O_3$  (transmittivity: 90% at 694 nm, 10% at 745 nm, 1% at 805 and 875 nm) were placed in the resonator, the pulse power decreased to 40 MW and the duration to 30 nsec. Three SRS lines were ob-

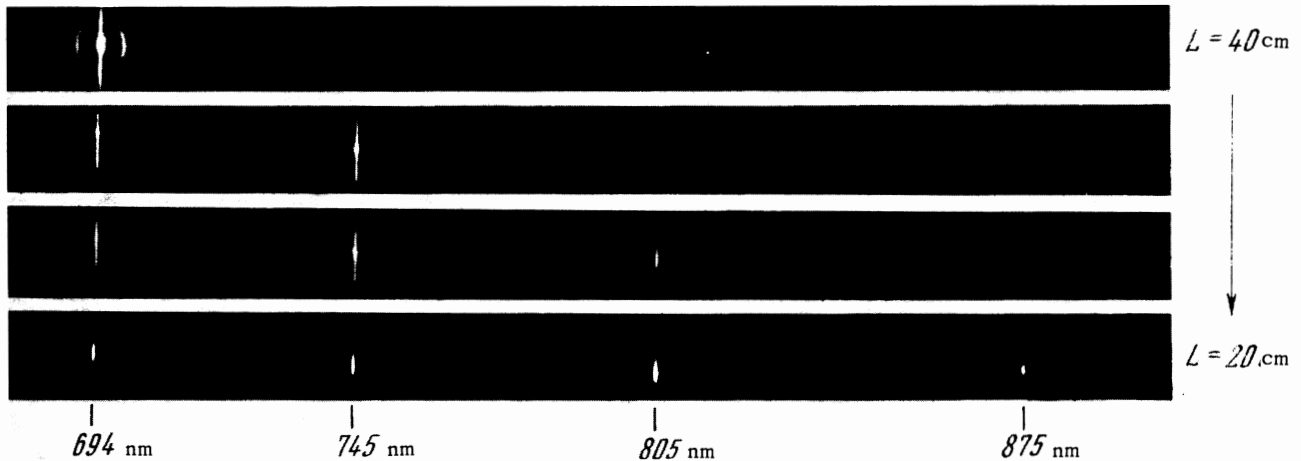

FIG. 2. The successive appearance of SRS in benzene in a longitudinal selective resonator whose length is decreased from 40 to 20 cm ( $l = 20$  cm,  $I_0 \approx 20$  MW/cm<sup>2</sup>).

served inside the selective resonator<sup>2)</sup>, with pulse duration 20 nsec and power about 10 MW. It was verified that decreasing the length of the selective resonator decreases the exciting-pulse energy required to overcome the detection threshold, and that the SRS harmonics appear gradually (Fig. 2).

The parameters of the setup of Fig. 1b, at which transformation of about  $10^{-4}$  of the laser pulse energy was observed, are listed in the table. In estimating the power of the exciting pulse we assumed that the radiation density is uniformly distributed over the resonator  $O_1 - O_2$ . This assumption is justified in the steady state for large reflectivities of the mirrors  $O_1$  and  $O_2$ , regardless of the transmittivity of the mirror  $O_3$ <sup>[17]</sup>.  $D$  was calculated, as before, without taking into account the losses in transformed radiation and assuming a uniform distribution of the power across the beam. At the maximum cell length,  $l = 60$  cm, a minimum threshold intensity of  $0.5$  MW/cm<sup>2</sup> was achieved (laser pulse energy  $\sim 0.1$  J).

##### 5. SRS IN A TRANSVERSE SELECTIVE RESONATOR (Fig. 1c)

The use of a resonator with an axis perpendicular to the exciting beam makes it possible to reduce the resonator length and to exclude the inhomogeneous ruby from the path of the transformed radiation. Such a transverse resonator is very convenient for the extraction of the trans-

formed frequency when the frequency shift from the original is small. The disadvantage is that the length of the active path  $l$  of the transformed radiation is determined by the cross section of the laser beam and cannot be increased without complicating the design of the cell. SRS in a transverse resonator was investigated with the ruby radiation polarized perpendicular to the plane passing through the direction of the exciting and scattered radiation. The setup was checked with a cell of length 0.5 cm along the laser beam, the beam diameter being 1.2–1.4 cm. The cell design was such that the minimum length of the selective transverse resonator was  $L = 37$  mm (or  $L_{\text{eff}} = 55$  mm), so that only about 1/3 of the resonator length was active. The reflectors  $O_3$  and  $O_4$  were dielectric mirrors similar to those in the resonator of the laser. Owing to the unfavorable relation between the active and inactive lengths of the transverse resonator, and to its small length  $l$  (losses are expressed sharper), the threshold power and energy required to observe SRS were higher than in the longitudinal selective resonator. At the conditions shown in the table, the threshold power was 18 MW for a pulse of 30 nsec duration. The value  $D = 20$ , calculated without allowance for losses and assuming uniform power distribution across the beam, was close to the theoretical value  $D_{\text{eff}} = 30$ .

As with the longitudinal selective resonator, we observed here an almost simultaneous appearance of three SRS lines when the energy of the exciting pulse was increased. The cross section of the transverse beam of the transformed radiation was nearly rectangular, of dimensions  $8 \times 4$  mm. Increasing the length of the transverse resonator increased the threshold energy. Figure

<sup>2)</sup>It is possible that there was also a transformation into higher harmonics which could no longer be registered by the spectrograph.

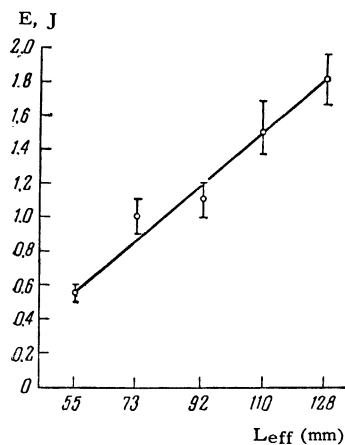

FIG. 3. Dependence of the threshold energy of the exciting pulse on the effective length of the transverse resonator, for the 745 nm line.

3 shows the dependence of the threshold energy of the exciting pulse on the effective length of the transverse resonator, whose parameters are listed in the table. Vertical lines mark the region of pulse energy in which the SRS was not reliably observed. The experimental dependence is close to that predicted theoretically, assuming that the loss of transformed radiation during one passage is small in comparison with the amplification.

## 6. STIMULATED BRILLOUIN SCATTERING IN A TRANSVERSE RESONATOR

In the first experiments on SRS in the transverse resonator, an undisplaced ruby line was observed besides the expected SRS lines, with intensity close to that of the scattered lines. It was checked by means of control experiments that this line corresponds to radiation along the axis of the transverse resonator. The radiation appeared in the cell after overcoming a clear-cut power threshold of the exciting beam. This threshold was a few times lower than for the SRS. The radiation was assumed to be due to stimulated Brillouin scattering (SBS, scattering from ultrasound waves). Some doubt was raised by the very low threshold power of the effect, because in earlier experiments<sup>[10,11]</sup>, where SBS was observed outside the resonator by focusing the beam, the threshold power was three orders of magnitude larger.<sup>3)</sup>

A Fabry-Perot interferometer was used to

<sup>3)</sup>The authors express their gratitude to V.I.Perel' for a discussion of experimental results. V.I.Perel's estimates of the threshold power agree satisfactorily with the results of the present work.

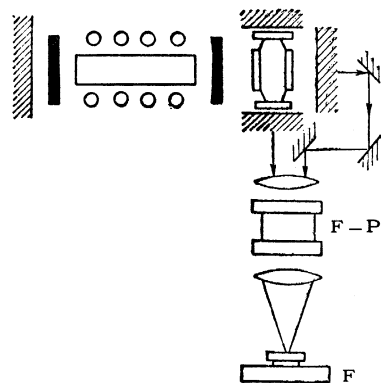

FIG. 4. Apparatus for the observation of SBS in a transverse resonator. F - P is a Fabry-Pérot interferometer (IT 51-30) (the distance between the reflecting plates is 6 mm), F is a camera using MZ film.

measure the spectral shift of the scattered radiation relative to the initial radiation. Some difficulty in the measurement was connected with the changes in laser frequency from pulse to pulse (by fractions of one  $\text{cm}^{-1}$ ). Therefore the initial and scattered radiation were analyzed together on one interference pattern. The diagram of the experiment is shown in Fig. 4. The initial radiation entered the interferometer symmetrically relative to its axis and formed a full system of rings. The scattered radiation entered with such an angular distribution that it formed mainly half-rings. This permitted reliable separation of the initial and scattered radiation without inhibiting the shift measurement. Such an interference pattern is shown in Fig. 5. The shifts found experimentally for carbon bisulfide and benzene were  $0.14 \pm 0.01 \text{ cm}^{-1}$  and  $0.15 \pm 0.01 \text{ cm}^{-1}$ . When comparing this with results by others one should take it into account that in our experiments the scattering was observed perpendicular to the laser beam. The angle of observation enters in the expression<sup>[10]</sup> for the shift  $\Delta\nu$  of the frequency of scattered light

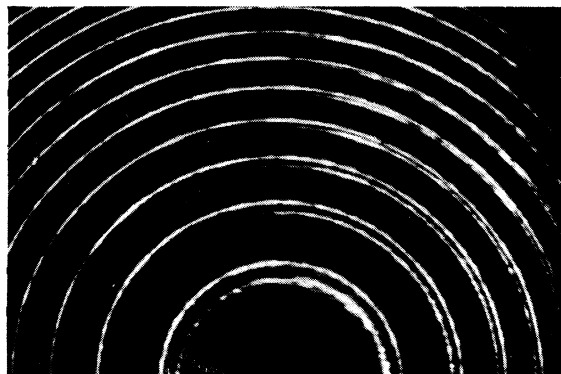

FIG. 5. Interference pattern of stimulated Brillouin scattering in carbon bisulfide ( $\Delta\nu = 0.14 \pm 0.01 \text{ cm}^{-1}$ ).

$$\Delta\nu = 2\nu \frac{v}{C} n \sin \frac{\theta}{2},$$

where  $v/C$  is the ratio of the velocity of sound in the medium to the velocity of light, and  $\nu$  is the frequency of the initial radiation.

SBS was observed also in nitrobenzene. A minimum power threshold (on the order of  $1 \text{ MW/cm}^2$ ) was recorded for carbon bisulfide. The power required for benzene was several times larger, and that for nitrobenzene was about the same. The last result is at some variance with [11], where it was found that the threshold power for SBS in nitrobenzene is much higher than in benzene.

The experimental results show that a transverse resonator is very convenient for the observation of SBS, permitting quantitative separation of the transformed radiation from the original one, and requiring a low threshold energy. We have learned that Takuma and Jennings [12] also used an off-axis resonator for these purposes. However the positioning of the resonator in [12] at a small angle to the laser beam called for a longer resonator, which greatly raised the threshold for SBS.

<sup>1</sup>V. A. Zubov, M. M. Sushchinskiĭ, and I. K. Shuvalov, UFN 83, 197 (1964); Soviet Phys. Uspekhi 7, 419 (1964).

<sup>2</sup>A. M. Bonch-Bruevich and V. A. Khodovoĭ, UFN 85, 3 (1965), Soviet Phys. Uspekhi 8, 1 (1965).

<sup>3</sup>F. J. McClung and D. Weiner, J. Opt. Soc. 54, 641 (1964).

<sup>4</sup>Akhmanov, Kovrigin, Kulakova, Romanyuk, Strukov, and Khokhlov, JETP 48, 1202 (1965); Soviet Phys. JETP 21, 801 (1965).

<sup>5</sup>Geller, Bortfeld, Sooy, and Woodbury, Proc. IEEE 51, 1236 (1963).

<sup>6</sup>H. Takuma and D. A. Jennings, Proc. IEEE 53, 146 (1965).

<sup>7</sup>H. Takuma and D. A. Jennings, Appl. Phys. Letters 4, 185 (1964).

<sup>8</sup>J. H. Dennis and P. E. Tannenwald, Appl. Phys. Letters 5, 58 (1964).

<sup>9</sup>R. Mercier and C. A. Roulet, Bull. techn. Suisse Romande 90, 316 (1964).

<sup>10</sup>R. Y. Chiao, C. H. Townes, and B. P. Stoicheff, Phys. Rev. Letters 12, 592 (1964).

<sup>11</sup>E. Garmire and C. H. Townes, Appl. Phys. Letters 5, 84 (1964).

<sup>12</sup>H. Takuma and D. A. Jennings, Appl. Phys. Letters 5, 239 (1964).

<sup>13</sup>R. W. Hellwarth, Phys. Rev. 130, 1850 (1963).

<sup>14</sup>R. W. Hellwarth, Appl. Optics 2, 847 (1963).

<sup>15</sup>R. C. C. Leite, R. S. Moore, and J. R. Whinnery, Appl. Phys. Letters 5, 141 (1964).

<sup>16</sup>G. Bret and F. Gires, Appl. Phys. Letters 4, 175 (1964).

<sup>17</sup>J. A. Fleck, J. Appl. Phys. 34, 2997 (1963).

<sup>18</sup>N. Bloembergen and Y. R. Shen, Phys. Rev. Letters 13, 720 (1964).