

EXCITATION OF HYPERSOUND IN QUARTZ

E. M. GANAPOL'SKII and A. N. CHERNETS

Institute of Radio Physics and Electronics, Academy of Sciences, Ukrainian S.S.R.

Submitted to JETP editor May 27, 1961

J. Exptl. Theoret. Phys. (U.S.S.R.) **42**, 12-15 (January, 1962)

A description is given of a method for excitation of longitudinal and transverse 10^{10} cps hypersonic waves in thick quartz bars.

UNTIL recently hypersonic waves (vibrations of 10^9 – 10^{12} cps) have been excited by optical methods using scattering of light on thermal vibrations of a medium. Optical excitation entailed great experimental difficulties and the frequency and amplitude of the hypersonic vibrations could not be controlled by an external agency.

A promising controllable method of hypersonic excitation is the technique of using the piezoelectric effect in quartz at microwave frequencies.^[1] Hypersonic vibrations at 9.3×10^9 cps^[2] and 2.4×10^{10} cps^[3] have been obtained by this technique. A quartz monocrystal was placed between two cavity resonators. The quartz was in the form of a thin cylindrical rod with its ends in strong electric fields concentrated in a small region within the resonators. One of the resonators was used to excite hypersonic and the other served as a receiver.

To avoid a considerable reduction of the resonator Q-factor and to prevent radiation of electromagnetic energy along the quartz rod from lowering the electric field intensity, the rod diameter d should be much less than λ_e , the electromagnetic wavelength in quartz. This condition sets an upper limit on the frequency of hypersonic produced by the piezoelectric effect.

The difficulty was avoided by exciting and receiving the hypersonic vibrations in the same cavity resonator; in this respect the method differed from Jacobsen's work.^[2] Monocrystalline quartz was used in the form of a bar of large cross section. By selecting a certain configuration of the hf electric field in the resonator it was possible to excite simultaneously longitudinal and transverse 10^{10} cps waves in the quartz bar.

When monocrystalline quartz is placed in the electric field of a cavity resonator, hypersonic vibrations are produced in a thin surface layer^[4] and are propagated into the interior of the sample in the form of plane transverse or longitudinal

waves. The hypersonic wave energy is proportional to the square of the electric field intensity at the surface of the quartz sample. It follows hence that for best results the resonator shape should be such as to produce strong electric fields at the quartz surface.

A coaxial resonator such as shown in Fig. 1 was used. It differed from Jacobsen's resonator^[2] in that it produced a strong nonuniform electric field concentrated in a ring aperture between the end of a cone 1 and a thin diaphragm 2 which served as the resonator cover. The quartz bar 3 measured $10 \times 10 \times 30$ mm and its x axis was directed along its length. The surfaces A and B of the bar were optically plane and parallel.

To prevent loss of electromagnetic energy through the bar from reducing the electric field intensity in the resonator, the bar was placed in a metal screening can 4. Microwave energy was supplied to the resonator along a waveguide 5 through a matching quarter-wave transformer 6

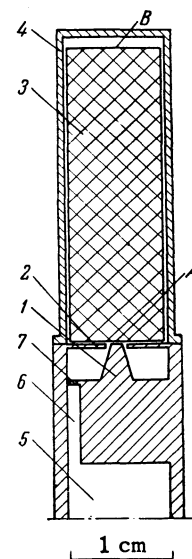

FIG. 1

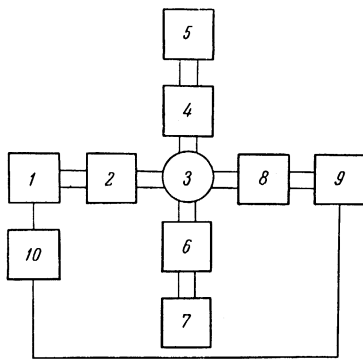

FIG. 2

and a coupling aperture 7. For a given microwave power the electric field intensities produced at the quartz surface were higher than those obtained by Jacobsen.^[2]

At room temperature hypersonic waves are strongly attenuated in quartz. Consequently, following Jacobsen,^[2] hypersonic was excited at liquid-helium temperature (4.2° K) with the resonator, quartz, and waveguide all placed in a helium cryostat.

Figure 2 shows a block diagram of the apparatus used to excite hypersonic waves. A pulse oscillator 1, working in the 3-cm band, supplied energy through an attenuator 2 of a hybrid ring 3, which served as a bridge. A nonreflecting load 4 and a wavemeter 5 were connected to one of the hybrid-ring arms. Another arm of the ring had the resonator 7 connected via a matching section 6. A superheterodyne receiver 8 with a balanced crystal mixer and an oscillograph 9 were connected to the measuring arm of the ring. The oscillator was controlled by a modulator 10 and produced pulses of 0.8 μ sec duration. The receiver sensitivity was 5×10^{-13} W and its pass band was 6 Mc.

When a bridge circuit is used it is necessary to protect the mixer from direct reception of strong microwave pulses from the oscillator. Balancing of the bridge by means of a matching section allowed a 100-fold reduction of the power reaching the receiver input from the oscillator.

When hf electric field pulses act on a thin layer of quartz next to the surface A, the piezoelectric effect produces hypersonic pulses. These pulses are propagated along the quartz bar, are reflected from the surface B and return to A where the sound energy is transformed back into electrical energy.

The reflection at the surface B produces a pulse signal with a delay equal to the two-way travel time of hypersonic waves in the quartz bar;

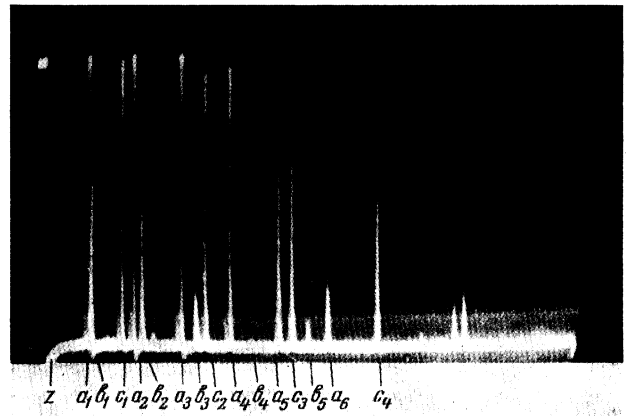

FIG. 3

the signal then travels to the receiver. Use of a bridge circuit avoids the necessity of two cavity resonators, which are difficult to tune when enclosed in a helium cryostat.

Three groups of equidistant pulses can be seen in the oscillogram shown in Fig. 3; they represent three hypersonic waves traveling at different velocities in quartz. The wave velocities are easily determined by measuring the time intervals between pulses in each group.

One group of pulses, represented by a_1, \dots, a_6 in Fig. 3, constitutes the fastest (5.7×10^5 cm/sec) longitudinal wave. The other two groups, designated b and c, constitute two coupled transverse waves traveling in the quartz at 5.1×10^5 and 3.5×10^5 cm/sec, respectively.

Excitation of both transverse and longitudinal waves in quartz can be explained as follows. The electric field of the resonator diminishes rapidly with distance from the diaphragm aperture (diameter 1.6 mm). Consequently deformations produced by the electric field have both longitudinal (along the x axis) and transverse components and produce the observed longitudinal and transverse waves along the x axis.

The measured values of the velocities of longitudinal and transverse waves agree, within an experimental error of 5%, with the values calculated by Borgnis,^[5] who used elastic constants of quartz determined by a static method.

The authors thank Member of the Ukrainian Academy of Sciences B. G. Lazarev for liquid helium supplied by the Physico-Technical Institute of the Ukrainian Academy of Sciences.

¹K. N. Baranskii, *Kristallografiya* 2, 299 (1957), *Soviet Phys. Crystallography* 2, 296 (1957).

²E. H. Jacobsen, Phys. Rev. Letters **2**, 249 (1959).

³E. H. Jacobsen, Proceedings of the International Conference on Quantum Electronics (September, 1959), Columbia University Press, New York 1960.

⁴H. E. Bömmel and K. Dransfeld, Phys. Rev. **117**, 1245 (1960).

⁵F. E. Borgnis, Phys. Rev. **98**, 1000 (1955).

Translated by A. Tybulewicz

2