

SOVIET PHYSICS

JETP

A translation of the Journal of Experimental and Theoretical Physics of the USSR.

SOVIET PHYSICS JETP

VOL. 37 (10), NO. 3, pp. 417-636

MARCH, 1960

PRODUCTION OF K^+ MESONS BY COSMIC-RAY PROTONS AT 3250 m ABOVE SEA LEVEL

M. Ya. BALATS, P. I. LEBEDEV, and Yu. V. OBUKHOV

Submitted to JETP editor December 3, 1958

J. Exptl. Theoret. Phys. (U.S.S.R.) **37**, 589-595 (September, 1959)

The spectrum of K^+ mesons in the momentum range up to 0.9 Bev/c produced by cosmic-ray protons was measured at an altitude of 3250 m above sea level (Mt. Alagez). The cross section for the above process is estimated.

EXPERIMENTAL SETUP

A diagram of the experimental setup is given in Fig. 1. Six layers of lead (I—VI), each 50 g/cm^2 thick, formed the matter in which K mesons were produced in the interaction of cosmic ray particles with lead nuclei. The K^+ mesons leaving the lead were detected by two liquid scintillation counters C_1 and C_2 , and fell upon an aluminum absorber A 40 g/cm^2 in thickness. If the K^+ meson stopped and decayed in the matter of counters C_3 and C_4 or in the lead absorbers D and D', the array detected the decay of the K^+ meson in those cases when at least one of the shower particles, produced in the same interaction as the K^+ meson, traversed counters C_1 and C_2 . It is clear that in such cases, K^+ mesons produced in stars with a small multiplicity were detected by the array with a smaller probability than K^+ mesons produced in stars with a large multiplicity. The estimate of the above effect will be considered later in the discussion of the results.

A triple delayed-coincidence circuit $C_1 + C_2 + C_3$ (C_4) selected the decay events within the time range $(7 - 45) \times 10^{-9}$ sec. The trajectory of the primary particle and the number of the lead layer in which the interaction occurred were determined by means of a 220-channel hodoscope. Thus, the energy of K^+ mesons was determined from their range in lead.

The time of decay of K^+ mesons, i.e., the time between the appearance of a pulse in the counter C_2 and of the pulse in the counter C_3 (C_4), was measured with a high-speed oscillograph devel-

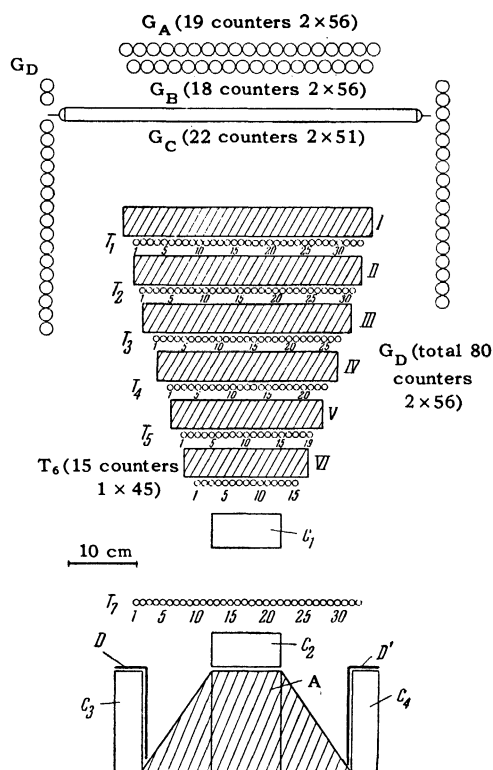

FIG. 1. General diagram of the array.

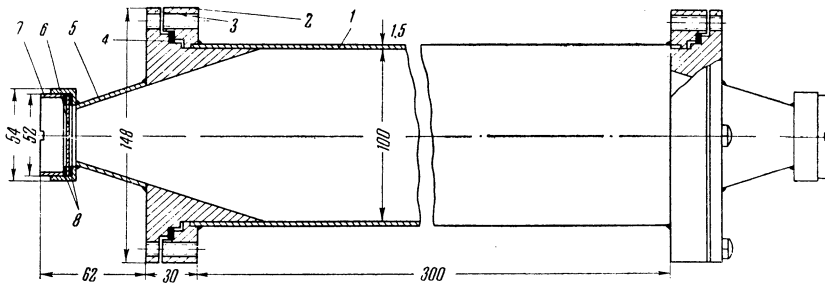

FIG. 2. Construction of the counter.
1 - counter body, 2 - flange, 3 - flange,
4 - fluoroplast washer, 5 - cone, 6 - quartz,
7 - screw, 8 - fluoroplast washer.

oped by us earlier.¹ The signal of triple coincidence $C_1 + C_2 + C_3$ (C_4) triggered the sweep of the oscillograph and served as the master pulse for the hodoscope. The screen of the cathode-ray tube and the hodoscope panel with neon lamps were photographed on film.

The hodoscope. The position and dimensions of the Geiger-Müller counters are shown in Fig. 1. Trays T_1 and T_7 determine the place of occurrence of the star and the trajectory of the K^+ mesons, and the counters of the groups G_A , G_B , G_C , G_D determine the number of particles falling on the hodoscope from above. The Geiger-Müller counters of group G_C , placed in the front and back of the array, are not shown in Fig. 1.

Each counter of the trays $T_1 - T_7$ and of the groups G_B and G_C was connected to a hodoscope cell with a neon lamp MGKh-90. The counters of the trays G_A and G_D were connected in groups, each of which was connected to a cell with a neon lamp. All neon lamps were placed on one panel, which was photographed.

Scintillation counters. One of the liquid scintillation counters used in the array is shown in Fig. 2. The counter consisted of a brass container filled with a solution of *p*-terphenyl in doubly-distilled, chemically pure benzene. The concentration of the scintillating substance amounted to 1.4 g/l and was chosen from considerations of small light absorption by the solution and sufficiently large amplitude of the light pulses. For better light collection by the photocathode of the photo-multiplier tube, the inner surfaces of the metal container were lined with polished aluminum foil. Counters C_1 and C_2 measured $300 \times 100 \times 50$ mm, while C_3 (C_4) measured $300 \times 150 \times 40$ mm. Photomultiplier tubes of the type FEU-2V were used in the counters.

Electronic circuits. A block diagram of the electronic circuitry is presented in Fig. 3. The photomultiplier signals from counters C_1 , C_2 , C_3 , and C_4 were fed after preliminary amplification and shaping to the input of the coincidence circuit.² The resolution curve of this circuit is given in Fig. 4. The method of measuring the time of decay of

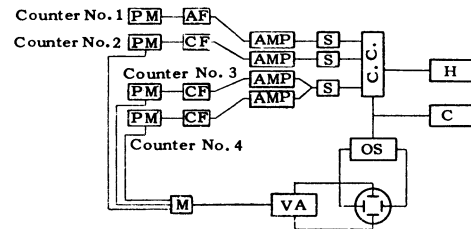
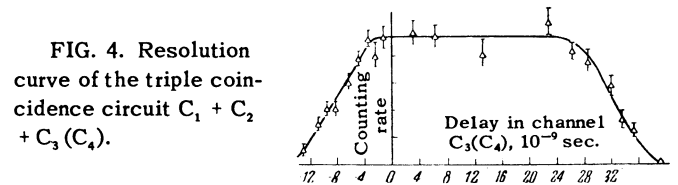

FIG. 3. Block diagram of the array. PM - photomultiplier of type FEU-2V, AF - anode follower, CF - cathode follower, S - shaping circuits, CC - coincidence circuits, H - hodoscope, C - camera control circuits, OS - oscilloscope sweep trigger, VA - vertical amplifier, M - photomultiplier signal mixer.



the K^+ mesons does not differ essentially from the method described earlier.³

To detect K^+ mesons with a mean life of 1.2×10^{-8} sec, the electronic circuit should have a sufficiently high resolving time. In order to measure the time spread of the scintillation-counter system, we determined the time between the pulses of the counters $C_2 - C_3$ and $C_2 - C_4$ corresponding to the simultaneous passage of a particle through the counters.

The data obtained are shown in Fig. 5. The accuracy of the time measurements by means of the counter system $C_2 - C_4$ was 2.2×10^{-9} sec and was determined essentially by the spread of

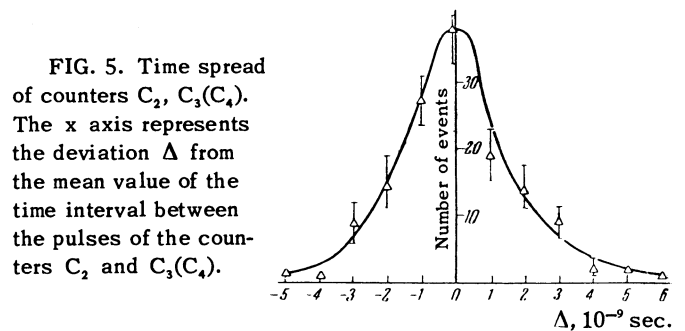

electron trajectories in the photomultiplier and by the counter size.

DECAY SCHEMES

Since the present experiment was not intended to identify the various decay schemes of K^+ mesons, the arrangement of the scintillation counters and the parameters of the electronic circuits were selected to record the most prevalent types of K^+ decay, $K_{\mu 2}$ and $K_{\pi 2}$.

The high energy of the decay μ mesons ($\epsilon_{\mu} = 152$ Mev, range $104 \text{ g/cm}^2 \text{ Pb}$) insures good detection by the scintillation counter C_3 (C_4) of a μ meson emerging at any point of the absorber A. The $K_{\pi 2}$ decay scheme was recorded by the array with a somewhat smaller efficiency, in view of the smaller range of the decay π mesons ($E_{\pi} = 108.5$ Mev, $R = 60 \text{ g/cm}^2 \text{ Pb}$), some of which stopped in the absorber and did not reach the counters.

In nuclear interactions in lead, comparatively many π mesons are produced together with the K^+ mesons (the mean life of the π meson is 2.5×10^{-8} sec).

Detection of the $\pi \rightarrow \mu$ decay ($E_{\mu} = 4$ Mev) was possible only when the π meson stopped and decayed in the scintillating substance of the counter C_3 (C_4) and when at least one particle of the shower passed through counters C_1 and C_2 . In such a case, three pulses appeared on the oscillograph screen — one due to the shower particle traversing the counter C_2 , one due to the π meson stopping in the scintillator of the counter C_3 (C_4), and one due to the μ meson, which loses not more than 4 Mev in the scintillating liquid. The first two pulses, from counters C_2 and C_3 (C_4), coincide in time.

In the reduction of the data, only the decay events with $A_2/A_3 \leq 5$ were considered, A_2 being the amplitude of the second pulse and A_3 that of the third pulse. This corresponds to a limiting energy π -meson of 20 Mev. It should be noted that such a selection criterion leads to omission of certain similar decays of K^+ mesons, although to a smaller degree, since the energy of secondary products in the K^+ decay is considerably larger.

The contribution of the $\mu \rightarrow e$ decay is small in view of the small value of the chosen time range as compared with the mean life of the μ meson ($\tau_{\mu} = 2.22 \times 10^{-6}$ sec). In addition, a large fraction of the decay electrons is absorbed in the lead absorbers D and D'.

The mean life of K^+ mesons as measured in the present experiment coincides with the values obtained by other authors.³⁻⁶ This confirms the small admixture of $\pi \rightarrow \mu$ and $\mu \rightarrow e$ decays.

MEASUREMENTS

Four experiments were carried out. In the first experiment, (a), 1200 hours long, the placement of the apparatus was as shown in Fig. 1. Data obtained in this experiment made it possible to obtain the range spectrum of the K^+ mesons in the interval $50 - 350 \text{ g/cm}^2 \text{ Pb}$, and also the production cross section of K^+ mesons for protons of cosmic radiation. Experiment (b) (200 hours), in which the three lower layers of lead were removed, was devoted to a comparison of the efficiency of the detection of K^+ mesons produced in various layers of lead. Lead layers I — III in experiment (b) differed from layers IV — VI in experiment (a) with respect to the detecting efficiency of the K^+ decay only in their geometry. The third experiment (c) (500 hours) differed from experiment (a) only in that the absorber A was removed in experiment (c). The array detected the decay of K^+ mesons stopping in the matter of the counter C_3 (C_4) and in lead absorbers D and D'. The fourth experiment (d) (196 hours) was carried out to determine the background due to air showers. The placement of the counters was the same as in experiments (a) and (b), but the absorber A and all the six layers of lead were removed. In this experiment, K mesons could be produced and come to rest only in the matter of the counters $C_1 - C_4$.

In reducing the experimental data of all four experiments, decay events satisfying the following conditions were selected:

- 1) The time between the appearance of pulses in counter C_2 and C_3 (C_4) lies within the range $(7 - 45) \times 10^{-9}$ sec, and the amplitude ratio $A_2/A_3 \leq 5$.
- 2) The production of K^+ mesons in the lead layers is not connected with an air shower.
- 3) The trajectory of the particle producing the star does not pass through the side Geiger-Müller counters of the hodoscope (group G_D in Fig. 1).
- 4) It is possible to determine the layer in which the interaction has occurred from the hodoscope picture.

DISCUSSION OF RESULTS

The number of decays detected in experiments (a), (b), and (c) are given in Table I. In experiment (d), no decay events satisfying the above selection criteria were detected during the 196 hours of operation.

Column 5 of Table I lists the data of the experiment (b), normalized to 1200 hours of operation, with account of the absorption of protons in the three layers of lead, for a nuclear-interaction mean free path equal to 160 g/cm^2 . Comparison

TABLE I

| No. of layer | Experiment (a) (1200 hrs) | | Experiment (b) p stars | | Experiment (c) p stars | | Momentum range of K particles (Bev/c) | Spectrum of K ⁺ mesons from experiments (a) and (b) |
|-----------------------------------|------------------------------|---------|---------------------------|---|---------------------------|------------------------|---------------------------------------|--|
| | p stars | n stars | 200 hrs | Normalized to 1200 hrs, taking into account proton absorption | 500 hrs | Normalized to 1200 hrs | | |
| I | 5 | 0 | 5 | 12 | 3 | 7 | 0.88±0.95 | 12±5 |
| II | 7 | 0 | 6 | 14 | 1 | 2.4 | 0.81±0.88 | 18±7 |
| III | 5 | 2 | 6 | 14 | 3 | 7 | 0.72±0.81 | 16±7 |
| IV | 10 | 3 | — | — | 3 | 7 | 0.63±0.72 | 37±14 |
| V | 15 | 7 | — | — | 3 | 7 | 0.54±0.63 | 63±11 |
| VI | 8 | 14 | — | — | 3 | 7 | 0.41±0.54 | 43±16 |
| Counters 1 and 2 and the absorber | 3 | — | 2 | 4.5 | | | 0±0.41 | 14±6 |

of the results of the experiments (a) (column 2) and (b) (column 5) shows that the probability of detection of a K decay is independent (within the limits of statistical errors) of the position of the lead layers relative to the absorber. The data of experiment (c), normalized to 1200 hours of operation, are given in column 7. By comparing these with the data of experiment (a) (column 2), we can determine the ratio of the detected decays in absorber A and in the matter of counters C₃ (C₄).

As already mentioned, the probability of the detection of K mesons stopping in the matter of the counters C₃ (C₄) depends on the multiplicity of the star in which the K meson was produced. This probability decreases with decreasing multiplicity of the star. It is clear that high-energy K mesons are produced with more penetrating particles than K mesons of lower energies. Therefore, the above effect will be especially important for the lower layers of lead.

The experimental data (Table I) for the layers IV – VI give the following ratio of the number of detected decays of K⁺ mesons in the matter of counters C₃ (C₄) and in absorber A:

$$N_{\text{counter}}/N_{\text{absorber}} \approx 1.8.$$

The calculated value of this ratio is

$$N_{\text{counter}}/N_{\text{absorber}} = 1.91/0.88 \approx 2.1$$

(see Table II). If we assume that the array detects only 50% of the decay events of K mesons stopping in the matter of counter C₃ (C₄), then the given ratio will be smaller by a factor of two and will equal 1.05. The total detection efficiency of K⁺ mesons is then smaller by 35%. Comparing the ratio $N_{\text{counter}}/N_{\text{absorber}}$ found in the experiment with the calculated one, we can conclude that the losses in the detection of decays produced in stars with a small number of prongs are small compared with the statistical error of the experiment. This is most probably due to the fact that most K⁺ mesons are produced in stars with a large number of penetrating particles.

In the upper layers of lead, a small number of K particles produced by neutrons was detected (Table I, column 3). This makes it possible to conclude that K mesons are predominantly produced by the charged component of cosmic radiation. The increased number of K⁺ mesons produced by neutrons in the lower layers of lead is due to the increase in the solid angle for primary particles. (For protons, the solid angle is limited by the counters of group G_D.)

The observed number of decays of K⁺ mesons

TABLE II

| | Weight of matter P, kg | $\Omega_{\mu}/4\pi$ | Ω_p , sterad | $P \Omega_p(\Omega_{\mu}/4\pi)$, kg-sterad |
|---------------------------------|------------------------|---------------------|---------------------|---|
| Absorber | 24.2 | 0.19 | 0.19 | 0.88 |
| Walls of counters and absorbers | 7.5 | 0.5 | 0.17 | 0.64 |
| Scintillator | 3.5 | 1 | 0.17 | 0.60 |
| Counter shoulders | 13.0 | 0.3 | 0.17 | 0.67 |

* $\Omega_{\mu}/4\pi$ is the solid angle for detection of K⁺ meson decay products, Ω_p is the solid angle for protons.

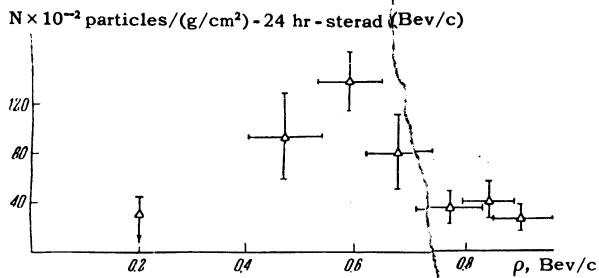
 FIG. 6. Momentum spectrum of K^+ mesons.

produced by the charged component in experiments (a) and (b) is given in the last column of Table I. The results are corrected in taking into account the absorption of protons in the lead layers and the nuclear interactions of K^+ mesons, with a mean free path⁷ $L = 640 \text{ g/cm}^2$. The data are normalized for the same width of the momentum range, 0.1 Bev/c. The momentum range of the K particles corresponding to each layer are shown in the next-to-last column of Table I.

The momentum spectrum of K particles is shown in Fig. 6. The decay curve constructed on the basis of all detected events is shown in Fig. 7. The mean life of the studied particles, as measured in these experiments, is $(10.0 \pm 1.2) \times 10^{-9}$ sec.

The cross section for the production of K^+ mesons by protons can be estimated under the following assumptions:

1) The detection probability of the decay, in the time range given above, is equal to 1, only if a secondary particle falls on one of the side counters C_3 or C_4 . The absorption of the decay products in the absorber and in the counter walls is neglected.

2) In the calculation of the solid angles, we shall assume that the K^+ -meson trajectory is a continuation of the trajectory of the star-producing particle. (This assumption is confirmed by the fact that the K^+ -decay detection efficiency is independent of the position of the lead layer with respect to the absorber.

3) The minimum proton energy necessary for the production of a K meson which can reach the

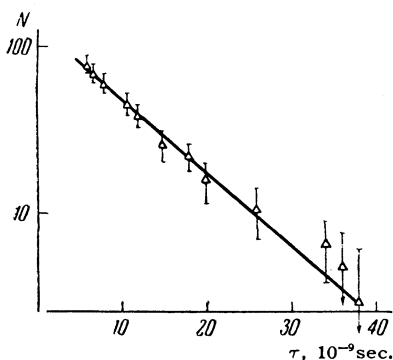
 FIG. 7. Integral distribution of mean lives τ .

absorber or the counters C_3 and C_4 is ~ 5 Bev. The main inaccuracy of the estimate lies in the uncertainty of this value. However, the small cross section for the production of K mesons for proton energies up to 5 Bev provides the basis for considering such a choice of the limiting energy close to the real one. The proton momentum spectrum at 3200 m above sea level is approximated by the function $N(p) dp = A^{-2.7} dp$, where⁸ $A = 0.9 \times 10^{-3}$ particle/cm²-sec-sterad (Bev/c), and the angular distribution of protons is of the form⁹ $N(\theta)d\theta \sim \cos^6\theta d\theta$. The cross section for the production of K^+ mesons by protons, calculated under the above assumptions, amounts to $\frac{1}{4}$ of the geometrical cross section and represents the lower limit of the actual value.

The results of the experiments show a sharp increase in the cross section for the production of K^+ mesons with increasing energy of the generating protons. From the shape of the given spectrum of K^+ mesons, it can be seen that the spectrum falls in the range of soft K^+ mesons. The observed number of K^+ mesons produced by protons and neutrons indicates the predominant production of K^+ mesons by the charged component of cosmic radiation.

In conclusion, the authors consider it their pleasant duty to express their gratitude to A. I. Alikhanov, G. P. Eliseev, V. A. Lyubimov, and A. G. Meshkovskii for discussion of the results, to A. I. Alikhanian for the facilities for carrying out the experiment at the cosmic station on Mount Alagez, and also to K. A. Zaitsev and A. N. Rozanov for help in carrying out the experiment.

¹ Balats, Lebedev, and Obukhov, Приборы и техника эксперимента (Instruments and Measurement Engineering) 2, 63 (1957).

² R. L. Garwin, Rev. Sci. Instr. 24, 618 (1953).

³ Balats, Lebedev, and Obukhov, JETP 31, 531 (1956), Soviet Phys. JETP 4, 436 (1957).

⁴ L. Mezzetti and D. W. Keuffel, Phys. Rev. 95, 858 (1954).

⁵ V. Fitch and R. Motley, Phys. Rev. 101, 496 (1956).

⁶ Alvarez, Crawford, Good, and Stevenson, Phys. Rev. 101, 503 (1956).

⁷ Lannutti, Chupp, and Goldhaber, Phys. Rev. 101, 1617 (1956).

⁸ L. I. Potapov and N. V. Shostakovich, Dokl. Akad. Nauk SSSR 106, 641 (1956), Soviet Phys.-Doklady 1, 85 (1956).

⁹ N. N. Kocharyan, JETP 25, 364 (1953).