

## The Dielectric Properties of Castor Oil at High Pressures

L. F. VERESCHAGIN, L. F. KUZNETSOV AND T. I. ALAIEVA

(Submitted to JETP editor June 25, 1955)

J. Exptl. Theoret. Phys. (U.S.S.R.) 30, 661-666 (April, 1956)

The dielectric constant and tangent of the loss angle of castor oil has been measured with varying pressures up to 9000 atmospheres, and at different frequencies. It is shown that the dielectric constant and the tangent of the loss angle pass through a maximum as the pressure is increased, which is connected with a change in the viscosity upon a change in pressure.

As is known, pressure can result in a change in the dielectric constant of liquids with polar molecules as a result of a change in the density. The equation of Debye

$$\frac{\epsilon - 1}{\epsilon + 2} \frac{M}{\rho} = \frac{4}{3} \pi N \left( \alpha_0 + \frac{\mu^2}{3kT} \right)$$

where  $\epsilon$  is the dielectric constant,  $\mu$  is the dipole moment,  $M$  is the molecular weight,  $\rho$  is the density,  $N$  is Avogadro's number,  $k$  is the Boltzmann constant), which we can use in considering the possible influence of pressure on the dielectric constant does not include, however, the possibility of the influence of pressure upon the electric polarizability  $\alpha_0$  and the orientation polarizability  $\mu^2/3kT$ . "The internal field" to which Lorentz has ascribed the value  $4\pi/3$ , can also change under pressure, which leads to an uncertainty in the treatment of the results.

At the present time a number of investigations of the dielectric properties of liquids under high pressures are known. For example, Kyropulos<sup>1</sup> investigated the influence of pressure up to 3000 atmospheres on the change of the dielectric constant. In this work, ethyl ether, carbon disulfide, chloroform, petroleum ether, carbon tetrachloride, and pyridine were investigated. It was found that the dielectric constant increased with an increase in the pressure for all of the liquids. The Clausius-Mosotti function for non-polar liquids

$$\frac{\epsilon - 1}{\epsilon + 2} \frac{M}{\rho} = \frac{4}{3} \pi N \alpha_0$$

is approximately constant except for carbon disulfide and ethyl ether. The author considers that under high pressure the molecules become markedly complex, which leads to an anomaly in the theoretical relations.

Chang<sup>2</sup> and Danforth<sup>3</sup> continued these investigations up to a pressure of 12,000 atmospheres, during which were conducted measurements of the dielectric constants of a number of liquids such as ethyl ether, eugenol, glycerine and others. It was established that the dielectric constant

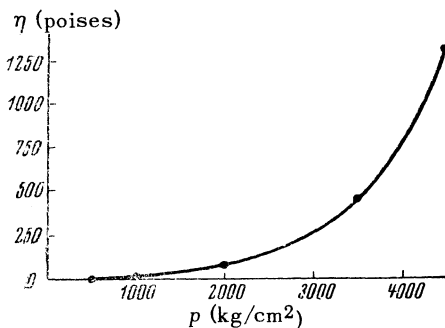
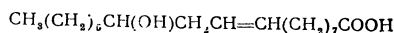

FIG. 1. Dependence of the viscosity of castor oil on the pressure,  $t = 30^\circ$ .

increases with the pressure and that at high pressures for strongly polar liquids a significant role in the polarization of the dielectric is played by the orientation term  $\mu^2/3kT$ , which must depend on the viscosity. The viscosity of liquids is in turn strongly dependent on the pressure. This led to Danforth's observing anomalies in the change of the dielectric constant of glycerine and eugenol with changes of the pressure.

This leads to an interest to study the influence of high pressure on the dielectric properties of polar liquids, in particular to study the influence of pressure on the tangent of the loss angle, the investigation of which can give additional knowledge about the behavior of polar molecules in fields of high frequencies under different pressures. Castor oil was the medium chosen for the study. This oil has important applications in engineering as a lubricating material and also in electrical engineering in industry as a dielectric material. The chief constituent of castor oil consists of glyceryl ricinic acid.



The viscosity of castor oil is strongly dependent on the pressure, as is seen in Fig. 1 which we have taken from the monograph of Zhohkovaskii<sup>4</sup>.

The presence of the dipoles of the molecules in castor oil and the strong dependence of its viscosity upon pressure give us reason to expect that

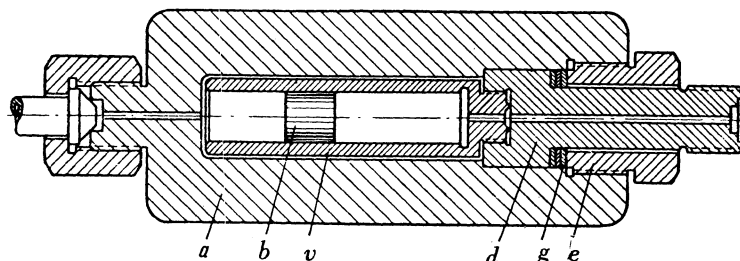

FIG. 2. Press Device: *a* – frame, *b* – plunger, *v* – cylinder, *g* – obturator, *d* – packing washers, *e* – sealing nut.

at high pressures the influence of the pressure on the dielectric constant and on the tangent of the loss angle will be especially noticeable.

#### EXPERIMENTAL PROCEDURE AND APPARATUS

The apparatus, with which the present investigations were carried out, consisted of a hydraulic compressor of ultra-high pressure, a reservoir,

which serves to even out the changes in pressure of the system, a press device, and a high pressure vessel inside of which the measuring condenser is located. The press device permits the separation of the liquid under investigation from the oil which comes from the compressor under pressure.

From Fig. 2 we see that this press device consists a steel cylinder with a cylindrical steel plunger, tightly ground in to inner surface of the cylinder. In Fig. 3 is

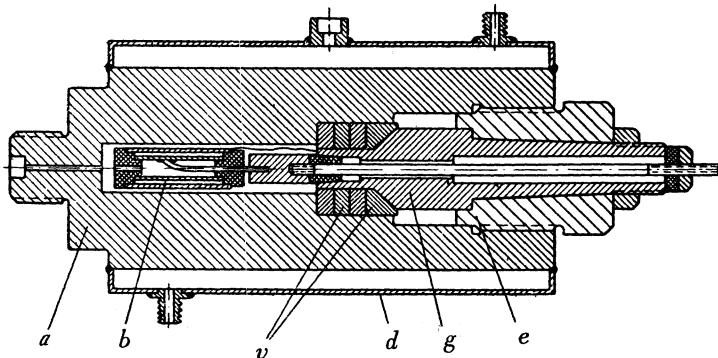

FIG. 3. High pressure vessel with the measuring condenser: *a* – frame, *b* – measuring condenser, *v* – jacket, *g* – electrode, *d* – nut, *e* – sealing washers.

shown the plan of the high pressure vessel together with the measuring condenser. This steel vessel is made of steel of brand 40X, hardened to a hardness  $R_c$  40-45. The outside diameter of this vessel is 70 mm, and the inside diameter is 10 mm. To maintain the temperature constant during the time of measurement a steel jacket is provided, through which oil was circulated controlled by an ultra-thermostat of Gepler. The temperature was maintained constant to an accuracy of  $\pm 0.3^\circ$  during the time of the experiment.

The measuring condenser is shown in Fig. 4. The condenser consists of two coaxial cylinders *a* and *b*, made of steel. The inside diameter of the outside cylinder equals 8mm, the outer diameter of the inner cylinder is 7.6 mm, the length of the cylinders is 34 mm. The coaxial cylinders are secured by the use of two ebonite bushings *v* and *g*. For filling the space between the walls

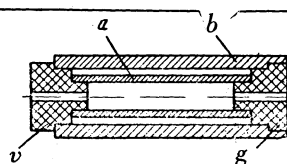

FIG. 4. Measuring condenser: *a*, *b* – coaxial cylinders, *v*, *g* – ebonite bushing.

of condenser with the liquid dielectric being investigated the ebonite bushings have a longitudinal opening, and the outer wall is perforated so that pressure can be transmitted with the greatest possible uniformity. The outer wall of the measuring condenser is exposed to the steel vessel and grounded. A connection from the inner wall of the condenser is accomplished by an electrode. The plan of this electrode is seen in Fig. 5, where a steel core-rod *a* passes through a cone *b* of high

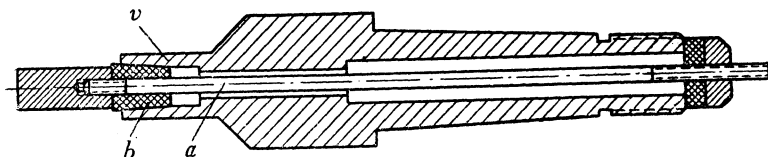

FIG. 5. Plan of the electrode: *a* - core-rod, *b* - cone  
*v* - obturator.

quality porcelain. A tight high pressure seal is accomplished by the liquid pressing the porcelain cone in a cone opening of the obturator *v*. Both surfaces (cone and cone mount) are carefully ground in with the aid of boron carbide.

The capacity of the electrode and conducting cable is 19.1 cm and does not depend on the pressure. Because the dielectric used is a solid, the its dielectric constant is practically unchanged with applied pressure. The conductor which is brought out through the electrode is connected to the inner plate of the condenser and by a shielded cable to a measuring instrument such as a *Q*-meter or dielectric meter. Upon change of the dielectric constant the dielectric meter changes; the principle of its construction is a method of comparing a beat frequency to the frequency of an auxiliary generator of constant audio frequency. The comparison of the beat frequency to the audio frequency generator is made on the screen of an electron oscillograph.

The frequencies which are compared give a Lissajou figure on the oscillograph screen (ellipse, figure eight). The measurement of dielectric constant is made up to frequencies of 1 mc.

The pressure is recorded with the aid of an indicating manometer constructed by Nagatkin with a scale up to a limiting pressure of 10, 000 kg/cm<sup>2</sup>.

Before installing the measuring condenser and the liquid to be measured in the steel vessel, the capacity of the lead alone and the capacity of the lead together with the measuring condenser, with air as

the dielectric ( $\epsilon = 1.005$ ), was determined. Comparing the capacity of the condenser filled with oil to the capacity of the same condenser filled with air at atmospheric pressure gave the value of the dielectric constant of the oil. This measurement performed for castor oil at atmospheric pressure and temperature of 20° gave the value  $\epsilon = 4.35$  which is in good agreement with values in the literature.

To be sure that during the time of the experiment the liquid being investigated does not mix with the liquid transmitting the pressure, the values of the indices of refraction for light of the investigated liquid are compared before and after the experiment. The index of refraction is determined with the aid of a refractometer.

#### EXPERIMENTAL RESULTS

The values of the dielectric constant of castor oil ( $\epsilon$ ) in relation to pressure are shown in Table 1, and the results of the measurement of the tangent of the phase angle ( $\tan\delta\%$ ) in relation to the pressure for different temperatures are given in Table 2. These data are shown in the form of curves in Figs. 6-9.

As we see in Fig. 6 where the change in the dielectric constant of castor oil with pressure at 32° is shown, the dielectric constant at first rises with rising pressure (with rise in the density of the liquid), then the curve passes through a maximum and succeeding values of  $\epsilon$  begin to decrease, in spite of the fact that the pressure continues to

TABLE 1

The dependence of the dielectric constant on pressure, temperature 32°.

Pressure $p_2$ in kg/cm <sup>2</sup>	$\epsilon$	Pressure $p_2$ in kg/cm <sup>2</sup>	$\epsilon$	Pressure $p_2$ in kg/cm <sup>2</sup>	$\epsilon$	Pressure $p_2$ in kg/cm <sup>2</sup>	$\epsilon$
1	4.35	2000	4.97	4400	5.15	6300	4.67
200	4.70	2400	5.08	4600	5.11	6800	6.55
425	4.74	2600	5.15	4900	5.04	7150	4.46
800	4.77	3050	5.22	5150	5.01	7400	4.41
1000	4.8	3450	5.25	5400	4.87	7625	4.25
1200	4.81	3650	5.25	5650	4.81	8150	4.17
1600	4.89	4050	5.22	6025	4.72	8750	4.11
						9050	4.05

TABLE 2

The dependence of the tangent of the phase angle on pressure.

$f = 464 \text{ kc/sec, } t = 7^\circ$		$f = 1.48 \text{ Nc/sec, } t = 7^\circ$		$f = 144 \text{ Kc/sec, } t = 5^\circ$	
$p$ in $\text{kg/cm}^2$	$\tan \delta$ in %	$p$ in $\text{kg/cm}^2$	$\tan \delta$ in %	$p$ in $\text{kg/cm}^2$	$\tan \delta$ in %
1	3,51	1	6,44	1	2,25
700	4,71	580	7,89	600	3,60
1000	6,06	1000	10,04	1000	4,42
1550	7,56	1500	10,44	1500	6,46
2000	9,76	2000	10,64	2000	7,70
4500	8,91	2500	10,74	2600	10,50
5050	6,71	3000	9,64	3000	11,30
5300	6,31	3500	9,24	4200	9,20
6000	5,20	4000	7,74	5000	7,48
6520	4,74	4500	6,44	6000	6,36
—	—	5120	5,54	7100	4,64
—	—	5620	4,84	—	—
—	—	6050	4,49	—	—

rise. The maximum of the curve relating  $\epsilon$  to pressure corresponds to a pressure of approximately 3600 atmospheres. The change of the dielectric constant with pressure is anomalous, because with an increase of the density of the liquid,  $\epsilon$  should rise also. The anomaly of the change in the dielectric constant with increasing pressure, apparently can be explained by a relaxation phenomenon which becomes significant as a result of the viscosity. At such pressure the dielectric constant upon an increase in the pressure should be effected by a significant rise in the relaxation time  $\tau$ . As is known, Debye<sup>5</sup> determined the relaxation time assuming that the molecular model could be a sphere with radius  $r$ . Then, taking Stokes' coefficient of drag  $\zeta = 8\pi\eta r^3$  for rotary motion of a sphere in a viscous medium with a coefficient of viscosity  $\eta$ , Debye obtained the expression  $\tau = (4\pi r^3/kT)$ . Clearly in an investigation of the liquid, castor oil, we cannot assume that the molecule has the shape of a sphere of radius  $r$ ; however we can assume a connection between the relaxation time and the viscosity of the liquid, as was established by Debye. In this way

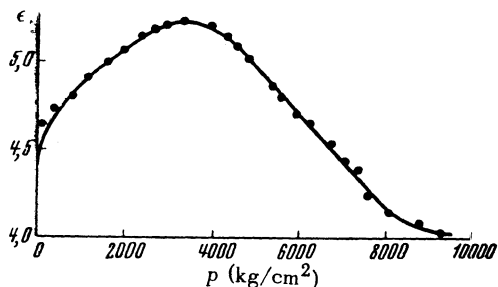

FIG. 6. The dependence of the dielectric constant of castor oil on pressure at a temperature of  $32^\circ$ .

the relaxation time will rise with an increase in viscosity, which at sufficiently high frequencies of the external field should lead to the molecules not being able to reorient through a large angle, near to  $180^\circ$ . And at sufficiently high values of viscosity the role of the orientation polarizability  $\mu^2/3kT$  becomes vanishingly small. This must lead to a diminution of the numerical value of  $\epsilon$ , which was determined previously from the value of the electric polarizability  $\alpha_0$  and the orientation polarizability  $\mu^2/3kT$ . In the part of the curve of Fig. 6, where  $\epsilon$  depends inversely on the pressure, clearly, the value of  $\epsilon$  will be determined by only the electric polarizability. It is interesting to note that  $\epsilon$  at pressures of the order of 9000 atmospheres is approximately 10% less than its value at atmospheric pressure.

Undoubtedly, measurement of the loss angle of the dielectric in the liquid investigated by us can give additional knowledge about the behavior of

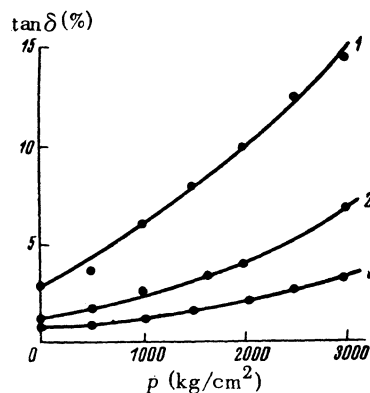

FIG. 7. The dependence of the tangent of the loss angle on pressure at a frequency of  $f = 148 \text{ mc/sec}$  at different temperatures: 1 -  $t = 22.2^\circ$ ; 2 -  $t = 50^\circ$ ; 3 -  $t = 74.2^\circ$ .

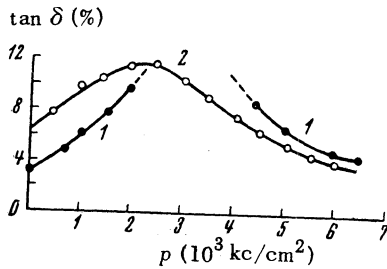

FIG. 8. The dependence of the tangent of the loss angle on pressure at different frequencies ( $t = 7^\circ$ )  
 1 -  $f = 464$  kc/sec; 2 -  $f = 1.48$  mc/sec.

polar molecules in liquids which are under high pressure. As is seen in Figs. 8 and 9, where the dependence of  $\tan\delta$  on the pressure at temperatures of  $5^\circ$  and  $7^\circ$  at different frequencies is shown, the value of  $\tan\delta$  in relation to the pressure passes through a maximum and then at even higher pressure diminishes. It is clear that the values of the phase angle are relatively small at both low pressures and very high pressures due to the strong interactions between molecules. In this way at low pressures  $\tan\delta$  will be small, then the value of the tangent of the phase angle will rise with an increase in pressure and pass through a maximum beyond which it will diminish, when the strong interactions between molecules reach the value where the external high frequency elec-

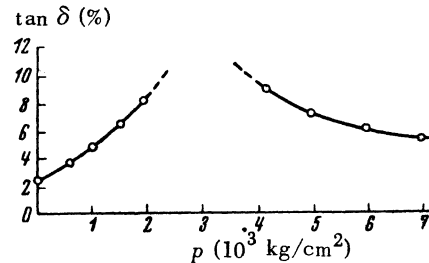

FIG. 9. The dependence of the tangent of the loss angle on pressure at temperature  $5^\circ$  and  $f = 144$  kc/sec.

tric field can not turn the polar molecules through a significant angle.

As was to be expected, at increased temperatures the measurements (see Fig. 7) lead to lower values of  $\tan\delta$ , which follows from the dependence of the viscosity of liquids on temperature.

We express thanks to laboratory mechanic S. J. Vlasov, who made the necessary apparatus.

<sup>1</sup> S. Kyropulos, *Z. Phys. Chem.* **40**, 507 (1926).

<sup>2</sup> L. T. Chang, *Chinese J. Phys.* **1**, 1 (1934).

<sup>3</sup> W. E. Danforth, Jr., *Phys. Rev.* **38**, 1224 (1931).

<sup>4</sup> M. K. Zhokhovskii, *Technical Measurement of Pressure and Vacuum*, Mashgiz, 1952.

<sup>5</sup> P. Debye, *Polar Molecules*.

Translated by F. P. Dickey  
 136

### Magnetic Analysis of the ( $d,p$ ) Reaction Products in the Investigation of Spin and Parity of Levels of the Daughter Nucleus

IU. A. NEMILOV AND V. F. LITVIN

*Radium Institute, Academy of Sciences, USSR*

(Submitted to JETP editor, July 25, 1955)

*J. Exptl. Theoret. Phys. (U.S.S.R.)* **30**, 686-689 (April, 1956)

The energy dependence of the intensity ratio of different proton groups from the reaction  $Al^{27}(d,p)Al^{28}$  has been utilized to determine possible spin and parity values of some levels in  $Al^{28}$ . The obtained results give for the level at 1.625 mev: even parity, spin between 0 and 5; at 5.128 mev: odd parity, spin between 0 and 6, and at 5.435 mev: odd parity, and spin between 1 and 4.

**B**Y observing the angular distribution of proton or neutron groups in stripping reactions it is possible to limit the possible values of spin and to determine the parity of excited states of the daughter nucleus.<sup>1</sup>

In this way the characteristics of excited states of light nuclei and of some low levels of heavier

nuclei have been determined. However, it is not possible to employ the usual techniques of determining the angular distributions in the region of higher excitation in heavier nuclei, where the levels lie close together. The methods usually employed are energy analysis by stopping in foils or by measuring of track length in thick photographic