

Resistance of Metals at High Current Densities

V. V. BONDARENKO, I. F. KVARTSKHAVA,
A. A. PLIUTTO, AND A. A. CHERNOV

(Submitted to JETP editor Feb. 16, 1954)

J. Exper. Theoret. Phys. USSR 28, 191-198 (1955)

Results are given of an investigation of the dependence of resistance of a few metals on current density. Comparison is made of experimental curves, presenting the dependence of resistance for copper, silver, platinum and other metals on the amount of energy introduced, with curves and calculations from tabulated data. For these metals, Ohm's law is maintained up to current densities of about 10^7 A/cm².

1. INTRODUCTION

IN the study of phenomena of electrically exploded metal wires, we were led to the investigation of the dependence of resistance of a few metals on current density. Many works¹⁻⁷ are devoted to this question, the authors of which have striven to obtain the highest possible current densities, with the aim of testing Ohm's law.

On the basis of classical electron theory of metals, it was pointed out^{5,6} that deviations of measurements from Ohm's law could become effective with current densities of 10^{10} to 10^{11} A/cm², or gradients of the field of 10^6 V/cm and higher. Such current densities are not realizable with contemporary experimental means. However, the further development of theory, as is well known, led to a reduction of the effective range of current density by a few orders of magnitude so that an opportunity for experimental verification of the theory was presented.

The available data in the literature on measurements of copper, silver, gold, tungsten, etc., show that up to a current density about 10^6 A/cm², deviations from Ohm's law are not noted. An exception must be made for the works of references 1 and 3, in which deviations from Ohm's law were given for current densities in a few units of 10^6 A/cm² for gold³, platinum and tungsten¹. Ignateva and Kalashnikov¹ indicated an increase in the resistance of platinum and tungsten in a few instances. As it was pointed out by Borovik² and Barlow⁴, and as is also evident from the presentation given

below, these results are incorrect.

Measurements at much higher current densities, as far as we know, have not yet been made. The method which we employed in investigations of electrical explosion of wires permits the obtaining of current densities up to 10^7 A/cm² and higher. By means of this method, the dependence of resistance of copper, silver, gold, platinum, aluminum, tungsten and iron on the current density was investigated.

2. METHOD OF MEASUREMENT

For investigation of the dependence of resistance of metals on the current density, use was made of a scheme customarily employed in experimental researches on electrical explosion of wires, i. e., discharge of a condenser through the wire being investigated. In these cases, when the energy of the condenser is large enough to evaporate the wire completely, evaporation follows in a very short time, and the gas is emitted with great speed producing the impression of explosion of the wire. This phenomenon is called electrical explosion of a wire.

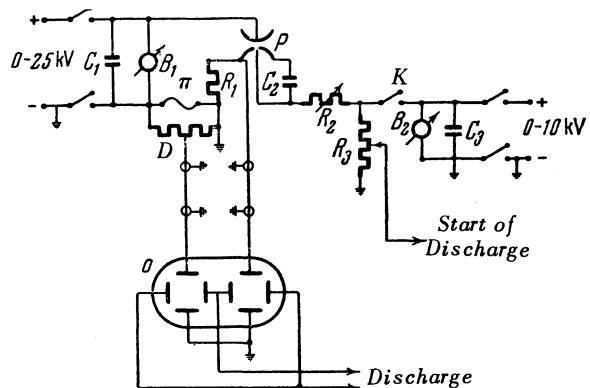

Fig. 1. Schematic diagram of the apparatus

The principal measuring scheme is shown in Fig. 1, where C_1 is the condenser for the explosion circuit, B_1 an electrostatic voltmeter, P a discharge gap with an initiating electrode, π the wire,

¹ L. A. Ignateva and S. G. Kalashnikov, J. Exper. Theoret. Phys. USSR 22, 385 (1952)

² E. S. Borovik, Doklady Akad. Nauk SSSR 91, 771 (1953)

³ P. W. Bridgman, Phys. Rev. 19, 131 (1922)

⁴ H. M. Barlow, Phil. Mag. 9, 1041 (1930)

⁵ J. J. Thompson, *Corpuscular Theory of Matter*, 1908

⁶ H. Margenau, Z. Phys. 56, 259 (1929)

⁷ H. R. Trautenberg, Phys. Z. 18, 75 (1917)

D the voltage divider and R_1 a so-called current resistor whose character and construction will be discussed later. On the right of the diagram is shown the circuit for initiating the discharge of the gap P ; in this circuit C_2 and C_3 are condensers, R_2 is a variable resistor, B_2 an electrostatic voltmeter and R_3 a resistor which has been set at a point at which the voltage serves to start up the sweep of the oscilloscope. The circuit of the initiator is brought into action by the switch K . In the lower part of Fig. 1 are shown the deflection plates of a twin beam oscilloscope with connecting cables. The parameters of the explosion circuit are: capacitance 8 to 10 microfarads, inductance 1 to 4 microhenries and voltage up to 10 KV.

The apparatus is activated in the following way. The capacitor C_1 is charged up by a rectifier to a variety of potentials, close to the breakdown potential of the discharge gap P . Further charging up to capacitor C_3 and closing of the key K brings the initiating circuit into action, which is connected through the resistance R_3 to the starting circuit of the common sweep of the twin beams of the oscilloscope used for simultaneous portrayal of the wire current and voltage. The sweep of the beams starts a few microseconds earlier than the initiated discharge P , so that the oscilloscope trace will be in the middle region of the sweep. On closing the key K , initiating the gap, a spark arises which almost instantaneously ignites the gap P , and the capacitor C_1 discharges through the wire. In this way, a voltage drop occurs in the "current" resistor R_1 proportional to the current through the wire. This voltage feeds one pair of the deflection plates of the oscilloscope through a coaxial cable. The voltage across the wire, after division in a voltage divider, feeds the other pair of deflection plates* by means of a second coaxial cable. The oscillogram was photographed by a "Kiev" photoapparatus with a "Jupiter 3" object lens on a sensitive photofilm RF¹. The maximum speed of the sweep in our experiment was about 25 Km/sec.

Calibration of the sweep of the oscillograph is accomplished by using a standard signal generator. For checking the uniformity and linearity of the sweep, both beams have a single sequence of signals simultaneously applied to them. An oscil-

* For an oscillogram of the voltage on the wire, the voltage divider is applied to balanced capacitors. A test for the absence of distortion was made by putting on the divider a steep front voltage pulse (about 10^{-8} sec), in which case the pulse front did not undergo noticeable distortion. For a criterion of accuracy, the oscillogram is also used to satisfy the law of conservation of energy in the circuit, within the limits of accuracy of the measurements.

logram of these signals showed that the speeds of the beam sweeps coincide with sufficient accuracy, and that the sweep is sufficiently linear, with the exception of small regions at the beginning and at the end of the sweep.

The voltage calibration for the oscillograph film is obtained by an exact measurement of a constant voltage applied to the divider**. The current calibration reduces to a determination of the voltage sensitivity of the deflection plate, and then the current is calculated by exact measurement of the important resistor R_1 . The sweep showed that, even for the most powerful pulses, the value of R_1 is unchanged. The inductance of the circuit is obtained by the well known method utilizing oscillograms of free damped oscillations of the circuit.

Typical oscillograms, showing the current and voltage on exploding wires, are shown in Fig. 2. Oscillogram a is for copper wire, length 6 cm, diameter 0.05 mm and a 3.5 microsecond sweep, and b is for a platinum wire, length 6 cm, diameter 0.1 mm and an 8 microsecond sweep. The upper curve shows the current in KA and the lower shows the voltage in KV. The capacity of the explosion circuit is 8.4 microfarads, the initial voltage is 5 KV and the inductance of the circuit is about 1 microhenry.

As is evident from these oscillograms, the explosion circuit is switched on at a certain time after the start up of the sweep. In the case of copper, the current grows from zero to some maximum and then it quickly falls to zero. This current break takes place without regard to the fact that the larger part of the initial voltage still remains on the condenser. In the case of platinum, the curve of current does not suddenly fall towards zero, but remains a plateau, along which the current and voltage are nearly constant. For platinum, a current break takes place after this step. Generally the current break is followed by a second pulse of current, associated with evaporation of the wire and gaseous discharge in vapors. This second pulse leads to full discharge of the condenser. The first pulse is of interest to us, because the wire is not yet evaporated.

The voltage curve at the beginning of the oscillogram shows the initial small inductive fall of potential. The potential rises with further rise of current. At the maximum of current the voltage continues to increase, and at the wire there occurs an excess voltage which, depending on the rate of change of current, can be several times larger than the initial voltage. After the break, the voltage remains constant.

** On discharging condenser C_1 (Fig. 1) through a high power resistor divider D (about 1000 ohms) the oscilloscope voltage remains constant for a few microseconds with a high degree of accuracy.

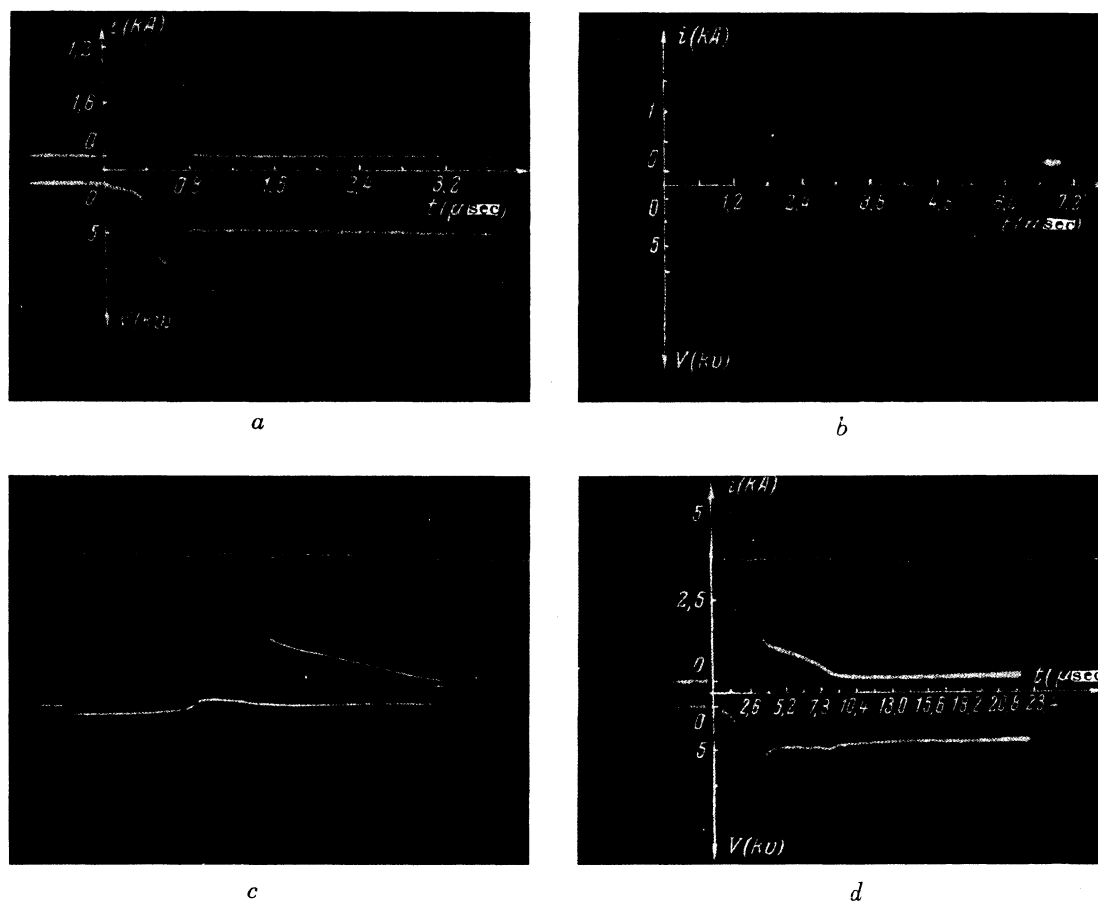

Fig. 2. Examples of oscillograms of current KA and voltage KV for electrical explosion of wires.

Oscillograms for silver, gold and aluminum wires are similar to the oscillogram for copper, that is, the characteristic of the plateau is absent. Oscillograms for iron, tungsten and molybdenum wires are similar to the oscillogram for platinum and clearly show a plateau.

The inductive fall of voltage is caused by the inductance of the wire itself and the contacts of the clamp. This can not be successfully avoided and we were obliged to introduce a suitable correction in the following way. After each explosion of the wire a correction oscillogram is taken in which the explosion is repeated with the very same kind of wire. Now the voltage divider is connected in another part of the condenser circuit possessing nearly the same inductance as that of the wire, but having negligible ohmic resistance[†]. Under these conditions the oscillogram of the voltage gives the amount of the induced voltage. Because the reproduction of the pulse of current and voltage was

[†] Equality of inductance is determined by calculation and is checked by the coinciding inductive fall of voltage at the beginning of the oscillogram.

good, these oscillograms were satisfactory for use in correcting the curve of voltage along each impulse. In Fig. 2, oscillogram c gives a typical example of a correction oscillogram.

The oscillograms of current show no inductive effect. This situation was due to the special construction of the "current" resistor R_1 . It was made out of a graphite tube with good metallic contacts at the terminals. For connecting into the circuit (Fig. 1), one end is grounded, but the voltage at the other end is taken off through a small coaxial conductor stretched along the axis of the graphite tube. In this way, this resistor acts as if it were a continuation of a coaxial cable without distortion. The absence of inductive distortion of the current was verified by taking an oscillogram under the condition that when the graphite tube was substituted by a copper tube it gave the same freedom from distortion.

In spite of the measures undertaken to prevent distortion, we still found it necessary to find a criterion which would demonstrate the correction of the oscillograms. Such a criterion is the law of

conservation of energy in regard to the circuit in the explosion process of the wire. At each moment of time t , there exists the equality

$$\int_0^t i(t) V(t) dt + \frac{Li^2(t)}{2} = \frac{C_1}{2} (V_0^2 - V_t^2), \quad (1)$$

where $i(t)$ is the current and $V(t)$ is the voltage across the wire at the moment t , L is the inductance of the circuit, C_1 is the capacity, V_0 is the initial voltage and V_t is the voltage of the condenser at the moment t . Thus the amount of energy given out by the condenser in the explosion process at the moment t , $C_1 (V_0^2 - V_t^2)/2$, should be equal to the sum of the energy discharging up to that moment in the wire in the form of Joulean heat,

$$\int_0^t i(t) V(t) dt \quad \text{and the energy of the magnetic}$$

field $Li^2(t)/2$. We neglect the electromagnetic radiation of the circuit and assume that the discharge of heat proceeds only from the wire. The resistance of the wire being tens, and at the end of the pulse, hundreds, of times greater than that of the remaining part of the circuit, permits a simple calculation to show that this hypothesis is equitable. Thus Eq. (1) should accurately represent an energy balance for the explosion of the wire. Upon examination of the oscillograms, one can apply Eq. (1) at the end of the pulse, when $i(t)$ is zero and $V(t)$ is constant. Then the equation is simplified, and takes the form

$$\int_0^t i(t) V(t) dt = \frac{C_1}{2} (V_0^2 - V_t^2). \quad (2)$$

If the oscillograms satisfy this equality with sufficient precision, one can assume that they describe the explosion process correctly. Repeated examination showed that our oscillograms satisfy this condition with precision within a few percent.

On the basis of such oscillograms, the energy W put into the wire is calculated at a moment t by the formula

$$W = \int_0^t i(t) V(t) dt. \quad (3)$$

Further, by means of tables of the specific heat $C_p(T)$, the wire temperature T is calculated by the formula

$$W = M \int_{T_0}^T C_p(T) dt, \quad (4)$$

where M is the mass of the wire and T_0 is its initial temperature. Finally, knowing the values $i(t)$, $V(t)$ and $T(t)$, it was possible to calculate the

resistance of the wire $R(W)$ as a function of the energy introduced.

In the following, the curve of dependence of R on the energy introduced is shown for different wires, using this method.

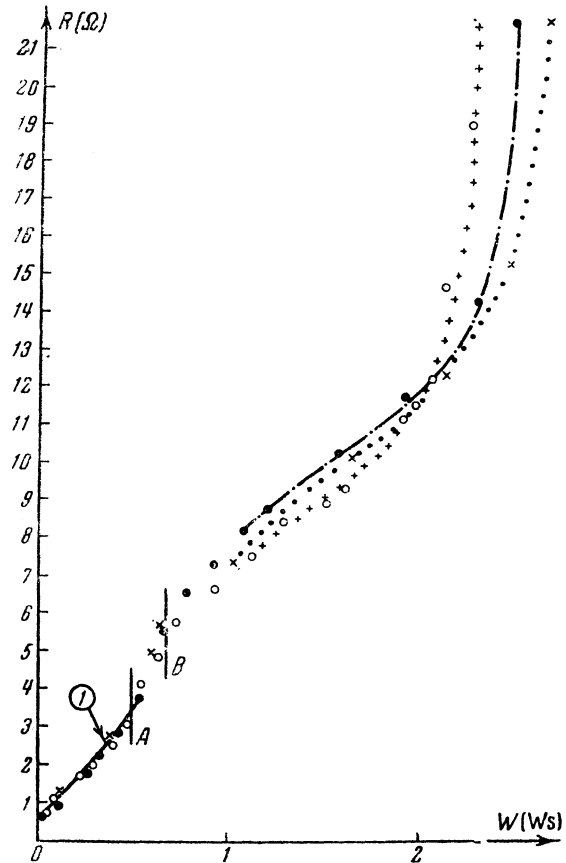

Fig. 3. Resistance curve for copper wire

3. RESULTS OF MEASUREMENTS AND THEIR DISCUSSION

Shown in Figs. 3,4,5 and 6 are curves picturing the dependence of resistance of the wire in ohms on the introduction of energy in watt-seconds. They were obtained from oscillograms of current and voltage, taken with maximum allowable speed of the sweep.

Figures 3 and 4 show the curves for copper and silver wires, having 6 cm length and 0.05 mm diameter.

Experimental points for copper correspond to initial voltages 3 KV, 4 KV and 5 KV and for silver 3.5 KV and 4KV with a capacity of 8.4 microfarads. Curves are given in Figures 5 and 6 for platinum and tungsten wires of 6 cm length and 0.1 and 0.2 mm diameter. The experimental points refer to 3,

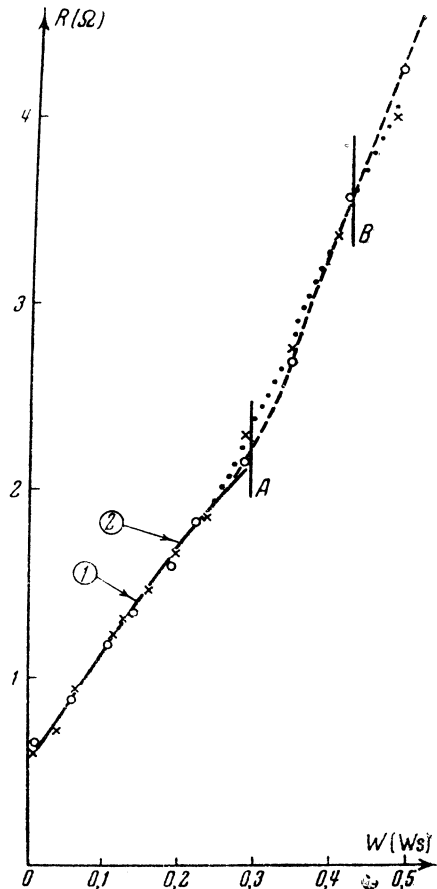

Fig. 4. Resistance curve for silver wire.

4, 5 and 7 KV for platinum, and 4,5,6 and 7 KV for tungsten. The parameters of the circuit for platinum are unchanged. In the case of tungsten, C_1 is 10 microfarads. The inductance of the circuit for all curves is a minimum.

The energy value $W = 0$ corresponds to room temperature. The initial value of the wire resistance (points of intersection of the curve with the ordinate axis) coincides well with the values of resistance of these wires measured in a bridge circuit at room temperature using weak currents. Points corresponding to the initiation of fusion (point A Fig. 5) and the end of melting of the wire (point B Fig. 5) are located in the interval shown by straight lines drawn parallel to the ordinate axis. These points are obtained by calculation from tabulated data. The circled numbers designate maximum and near maximum values of current density for a given wire. In Fig. 3, No. 1 indicates a current density of 6.5×10^7 A/cm² for copper. In Fig. 4, No. 1 indicates a current density of 5.9×10^7 A/cm² for silver and No. 2 to 6×10^7 A/cm². In Fig. 6 for tungsten, the points are 1.3×10^7 A/cm²

and 1.5×10^7 A/cm². In Fig. 5 for platinum, both points indicate a current density of 2.5×10^7 A/cm². Analogous curves and the same order of current densities are obtained for gold, iron and aluminum.

It should be noted that at points with maximum current density, the temperature of the wire does not exceed a few hundred degrees. With a lowering of the current density the temperature of the wire becomes lower. With temperatures of a few tens of degrees we still have current densities of about 10^7 A/cm² for copper and silver. In addition the trace of the curve $R = R(W)$ for platinum and tungsten is not changed even if the explosion of the wire takes place at the temperature of liquid air.

The continuous curves in the figures (from the origin to point A) are calculated curves. They are computed for each wire on the basis of tabulated data and picture the dependence of resistance on the energy for small current densities. As is evident, in the limits of accuracy of our measurements (5 to 7%) the experimental points for all metals investigated agree well with these curves. From this can be drawn a basic inference, that the resistance of metals: copper, silver, gold, aluminum, platinum, tungsten and iron, in the solid phase below the temperature of fusion, does not depend on the current density up to the value of 10^7 A/cm².

It is hard to say anything definite with reference to the dependence of resistance on the introduction of energy into the region from the beginning of fusion and higher. At the beginning of this region there is a rapid rise of resistance, increasing with the introduction of energy for nearly all metals. Experimental points for various voltages have a noticeable scatter. However it is possible to draw the conclusion that, at points of fusion, platinum, tungsten and iron show a region in which their resistance is almost independent of temperature. This shows that, in the liquid phase, these metals are characterized by a very small value of the temperature coefficient of resistance. As concerns copper, silver and gold, the rise rate of their resistance at the completion of fusion is in the direction given above, either decreasing not at all, or decreasing insignificantly (Figs. 3 and 4). However, with longer wires (12 cm and longer) the oscillograms for these metals show clearly the presence of discrete steps, sloping more or less than for platinum, tungsten and iron. In the qualitative example in Fig. 2 the oscillogram is given for silver 0.15 mm diameter and 24 cm length, with $C_1 = 10$ microfarads and 6 KV. The presence of

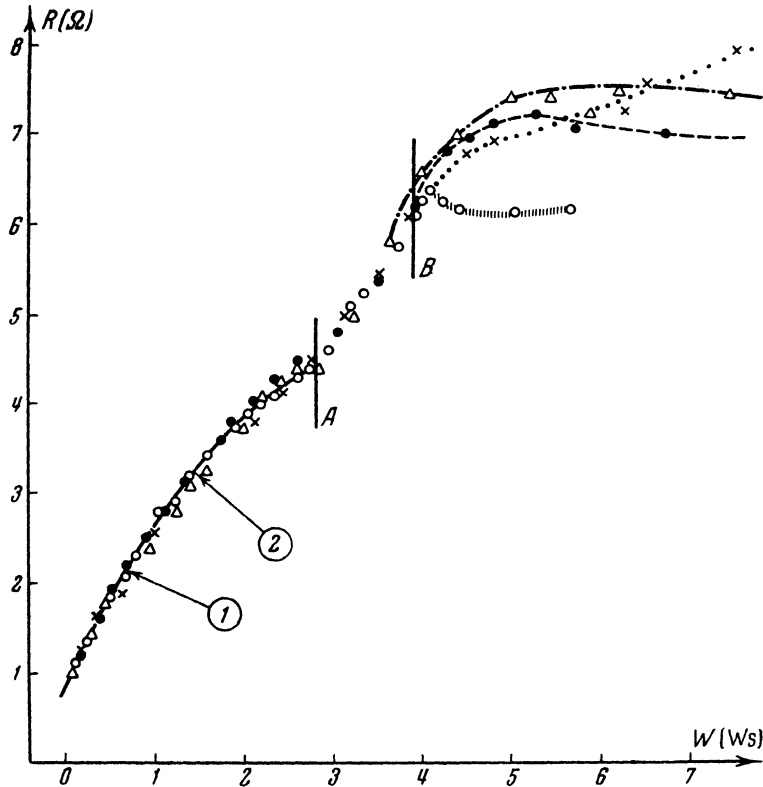

Fig. 5. Resistance curve for platinum wire.

○ — $V_0 = 3$ kV; ● — 4 kV; △ — 5 kV; × — 7 kV

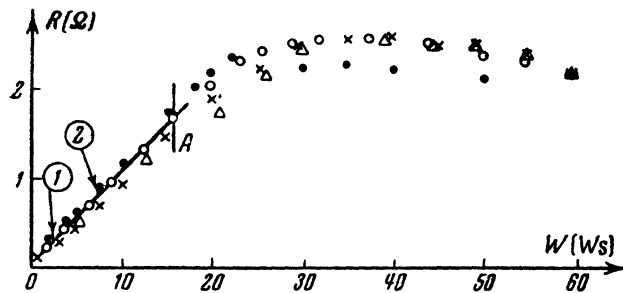

Fig. 6. Resistance curve for tungsten wire.

○ — $V_0 = 4$ kV; △ — 5 kV; × — 6 kV;
● — 7 kV

these little steps leads to the conclusion that in these metals in the liquid phase also, the temperature coefficient of resistance is smaller than in the region of the fusion process.

It should be noted that from the curves $R = R(W)$ in the transitional region from the solid to the liquid phase (at point A) and further in the liquid

phase, for different conditions of explosion (different initial voltage, current density along the curve, etc.) the conclusion can be drawn that the resistance of metals in these regions does not depend on current density or other factors, and is defined, within the limits of accuracy of the experiment, as soon as energy is introduced. Hence Ohm's law is valid in the transitional region and in the liquid phase.